

## 1009/3x40/1953

Morse light 3x40W 230V E27 IP56 clear cover

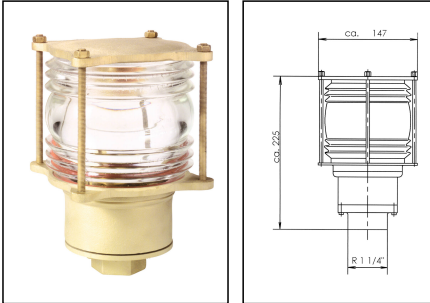

Products may differ in size, colour and appearance to those shown. If you require further information or customisation, please contact us directly.

<b>WISKA-Order no.</b>	50012844
<b>Type</b>	1009/3x40/1953
<b>Material</b>	Brass
<b>Material globe/diffuser</b>	Glass
<b>Globe colour</b>	Clear
<b>Wattage</b>	120 W
<b>Power<sup>^</sup></b>	3 x 40 W
<b>Voltage max. (V)</b>	230 V
<b>Protection class</b>	IP56
<b>Operational areas</b>	Outdoor
<b>Temp. range min</b>	-25 °C
<b>Temp. range max</b>	45 °C
<b>Lampholder</b>	E27
<b>Number of lampholder</b>	3 ST
<b>Lightsource</b>	Incandescent lamp
<b>Lightsource incl.</b>	No
<b>Sector</b>	360°
<b>Mounting</b>	Upside
<b>External dimensions LxWxH</b>	225x147mm
<b>Weight</b>	4,78 kg
<b>Tariff number</b>	94051990

Equipment:

- Fresnel lens, clear
- Connection thread R1 1/4"

Your Contact:

**WISKA Hoppmann GmbH**  
Kisdorfer Weg 28 · 24568 Kaltenkirchen · Germany  
☎ +49-4191-508-0 · 📠 +49-4191-508-209  
contact@wiska.de · www.wiska.com

**Spare parts**

<b>SP-1953 Nipple lampholder R 3/8" E27</b>	22000276
<b>SP-1909/clear</b>	22000317

12.05.2026

Your Contact:

**WISKA Hoppmann GmbH**

Kisdorfer Weg 28 · 24568 Kaltenkirchen · Germany

☎ +49-4191-508-0 · 📠 +49-4191-508-209

contact@wiska.de · www.wiska.com

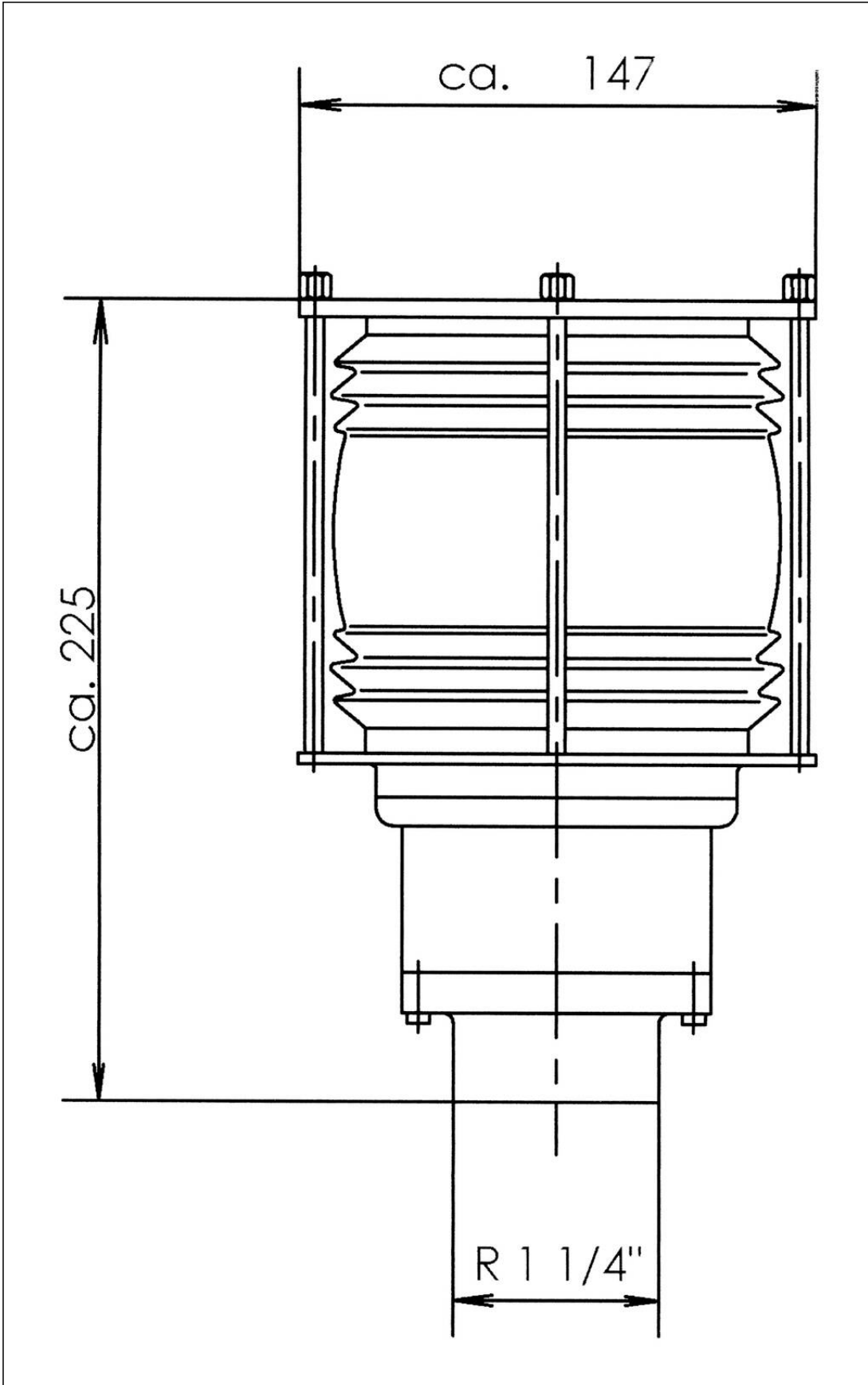

Your Contact:

**WISKA Hoppmann GmbH**

Kisdorfer Weg 28 · 24568 Kaltenkirchen · Germany

☎ +49-4191-508-0 · 📠 +49-4191-508-209

contact@wiska.de · www.wiska.com