



OPERATING INSTRUCTIONS

SEARCHLIGHT
SH400/575
230 V 50/60 Hz

WISKA Hoppmann & Mulsow GmbH

Kisdorfer Weg 28 • D-24568 Kaltenkirchen
Tel. +49 (0) 4191/508-100 • Fax +49 (0) 4191/508-249
Internet www.wiska.de • E-Mail wiska@wiska.de

SH400-575 Rev.230903E

Contents

1. ABOUT THIS MANUAL	4
1.1 Warning symbols and markings used in this manual	4
1.2 Who should read this instructions	4
2. SAFETY	5
2.1 General information	5
2.2 Working with Metal Halid lamps	5
2.3 In case the lamp breaks	6
2.4 Protective measures	7
2.5 Operating requirements	7
2.6 Maintenance / cleaning	8
3. OVERVIEW	9
3.1 Assembly drawings	9
3.2 Technical specifications	10
3.3 Unit nameplates	12
3.4 Dimensions	12
3.5 Circuit diagram	16
4. INSTALLATION.....	18
4.1 Unpacking the unit	18
4.2 Installation.....	18
4.3 Electrical connections	20
5. OPERATION.....	21
5.1 Control unit RCU.....	21
5.2 Turning on the searchlight	21
5.3 Turning off the searchlight	22
6. MAINTENANCE	23
6.1 Cleaning.....	23
7. REPLACING DEFECTIVE PARTS	23
7.1 Before you begin.....	23
7.2 Construction overview.....	24
7.3 Changing the lamp.....	25
7.4 Changing the primary reflector.....	27
7.5 Replacing the secondary reflector	28
7.6 Replacing the ignition unit.....	29
8. DISPOSAL	30
9. SPARE PARTS	31

1. About this manual

1.1 Warning symbols and markings used in this manual



Danger! Failure to observe this warning poses the risk of personal injury or death.



Danger of electrical shock! Failure to observe this warning poses the risk of personal injury or death from electrocution.



Gloves are recommended to fulfil this step in order to protect yourself or the material handled



Attention! Failure to observe this precaution poses risk of damage to environment and the product.

1, 2, 3, ... **Operating instruction** which are to be followed in a certain order are numbered.

- **Operating instructions** consisting of only a single step or of steps which can be carried out in any order are set off by a bullet point.

→ **Confirmation messages** in response to completed operation steps are preceded by an arrow.

- **Listing items** are preceded by a dash.

1.2 Who should read this instructions

These operating instructions are intended for all personal assigned to install maintain and operate the searchlight.



Danger of electrical shock! All electrical work related to installing and repairing the searchlight should only be carried out by qualified electricians.

2. Safety

Be sure to observe the following safety instructions. Failure to do so will pose danger to yourself and others.

2.1 General information

Intended use

The searchlight SH400/575 is designed to shine a spotlight on distant objects. The searchlight has a range of up to 3460m.

The searchlight is designed for use on ships, in particular for polar voyages through icy waters.

Due to its high intensity, the searchlight is not to be used to illuminate persons near the searchlight.

It is not designed for lighting rooms on the ship or in buildings.

Danger! The searchlight should not be altered or modified in any way due to the danger this poses to persons and damages which may occur to the searchlight. Failure to observe this will void the approval certificate.

Only original spare parts may be used.

Use of unauthorised spare parts will void any warranty.



Danger of burns! Never touch the searchlight during operation. The housing may reach temperatures as high as 180 °C. Always allow the searchlight to cool down before carrying out maintenance work or repairs. In case of burns, immediately cool the burned area and get medical help.



Danger of blinding! Never look into the source of light during operation. This poses a danger to your eyesight. Never point the searchlight at people.



Danger of crushing! Dander of cutting! Be sure that there are no persons directly next to the searchlight before rotating or tilting the searchlight. Persons standing near the searchlight may get limbs caught between the searchlight and base and serious injuries may result.



2.2 Working with Metal Halid lamps



Danger of explosion! Metal Halid lamps carry a high internal pressure during operation. The internal pressure during operation may be in an extend of 200 bar.

For this reason the following safety precautions must be observed when working with Metal Halid lamps:

Transport

- Always store and transport Metal Halid lamps in a way that the glass body of the lamp can not break.
- Also, after you have replaced a defective lamp store the used one in a safe place that it does not break.
- In case a lamp has broken follow the guidelines given in chapter 2.3 *In case the lamp breaks*.

Operating the lamp

- Never touch the lamp bulb with your bare fingers. Before mounting the lamp, remove any fingerprints smudges using a non-abrasive, lint-free cloth and alcohol solution. Use one way gloves to handle the bulb.
- Check the lamp for any scratches, cracks or signs of damage. Do not use damage lamps.

Service life

Metal Halid lamps have a average life of about 750 operating hours. The real service life depends on the relation between duty cycle and on-time.

Disposal

Metal Halid lamps contain toxic materials such as mercury, which are toxic for the environment and for human health. For this reason they may be disposed only under the European rule:

EWC-Code 2001 21 "Fluorescent tubes and other mercury containing waste"

as hazardous waste, in Europe. They must be delivered to the Hazardous waste disposal centres.

In other countries you must follow appropriate rules of that country.

Metal Halid lamps may not be destroyed under any circumstances.

Risk of health

Breathe in of mercury or mercury derivatives as dust or vapour may seriously damage your health. Beside of breathing in mercury can also be absorbed via your skin.



2.3 In case the lamp breaks



To minimise the risk of health in case that a lamp breaks or explodes we recommend the following guideline

- Every person in the direct proximity should leave the room quickly in order to avoid to inhale in mercury vapour.
- Carefully vent the room for about 20 to 30 minutes.
- After the lamp has cool down and, in any case before turn on the searchlight again, all remainder of mercury inside of the searchlight must be cleaned off mechanically.



To avoid skin contact use one-way gloves. Liquid mercury can also be taken away with off-the shelf absorption media (based on activated carbon).

2.4 Protective measures

Temperature

- To avoid moisture accumulation and facilitate ignition, a minimum temperature of 6 °C inside the lamp housing is required. To ensure that the minimum temperature is maintained, the searchlight housing is equipped with a thermostat- controlled heater. The heater also protect the searchlight from freezing.
- To protect the optional drive unit from freezing, the FL51 or FL20 pan and tilt unit can also be equipped with a thermostat-controlled heating unit.



Attention! To ensure that the minimum temperature is maintained during cold weather conditions:

- Keep the searchlight ready for operation by leaving the main switch S8 in ON condition. Turn on the searchlight only by means of the switch S1, which may be located on the remote control unit or may exist as a separate switch.
- Do not turn on the searchlight immediately if power has been cut off for a prolonged period of time while the temperatures were at 6 °C or less. First, place the searchlight in standby mode by switch S8 and wait until the minimal internal operating temperature has been reached inside the housing.

Radiation/ Emission of dangerous particles

- Metal Halid lamps emit UV light which is hazardous to your eyes. The special design of the searchlight prevent direct eye contact with the arc searchlight.
- If a Metal Halid lamp should explode during operation, the robust housing will stay intact and prevent hot glass shards from being expelled.

2.5 Operating requirements

Protection Class

The searchlight, power supply unit and the optional drive unit have an IP 56 protection class rating (dust-protected, heavy seas and powerful water jets). To maintain this protection class, all electrical cables may only be led in through appropriate screw- connected cable fittings.

Requirement for placement

Where to install

- the searchlight: under normal operating conditions the

housing of the searchlight will reach temperatures up to 180 °C. Mount the searchlight only in an environments which can resist this heat. To rule out all potential danger: do not store any explosive or easily inflammable materials in the immediate area of the searchlight. Such materials include gasoline, paper and paint.

- The power supply unit PSUH: Install the PSUH at a cool place which is not exposed to direct sunlight, vented hot air or other dissipated heat from fuel tanks



Attention! The searchlight and power supply unit PSUH are operating under high voltage. To prevent electromagnetic interference with the compass, make sure an appropriate distance is maintained between the searchlight, the power supply unit PSUH and the compass. Also, do not run cables in the direct proximity of the compass.

2.6 Maintenance / cleaning

Before carrying out maintenance or cleaning work:

- Turn off the main switch.
- Make sure the entire electrical system is dead.
- Wait until the searchlight has cooled down.

3. Overview

3.1 Assembly drawings

Basic configuration

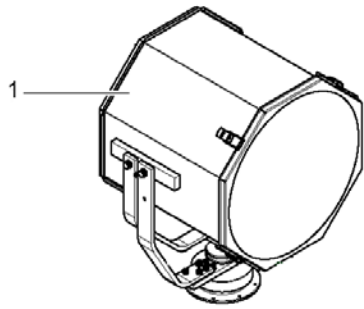

Configuration with drive unit FL51 and FL20 and with remote control unit RCU

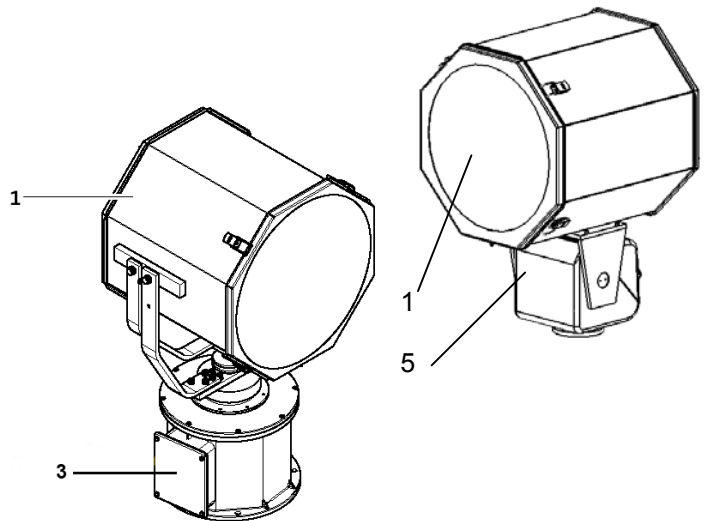
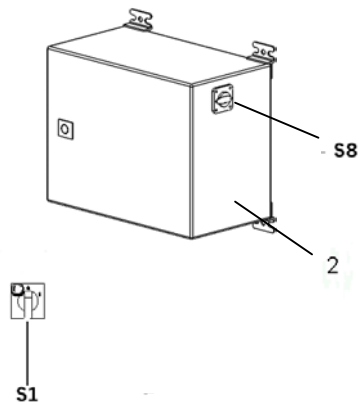

- 1 Searchlight
- 2 Power supply unit PSUH
- 3 Drive unit FL51
- 4 Control unit RCU for FL51 /FL20
- S1 ON/OFF switch for searchlight
- S8 Main power switch
- S2 ON/OFF switch for drive unit
- 5 alternative drive unit FL20

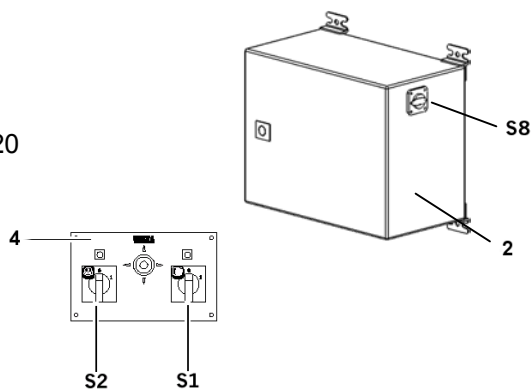

3.2 Technical specifications

Type SH400/575, FL51 230 V 50/60 Hz
 Manufacturer WISKA Hoppmann & Mulsow GmbH

Searchlight	
Lamp:	
Type of lamp	Metal Halid lamp
Illumination	12 Mio. cd
Range	3460 m
Diffusion angle	6 ° I/10
Lamp power	575 W
Average service life of lamp	750 h
Glass parabolic reflector	400 mm
Secondary reflector	100 mm
Fixed focus	
Housing:	
Material	steal 1.4301
Colour	RAL 9016
Diameter	472 mm
Depth	505 mm
Weight	25,5 kg
Protection class	IP 56

Power supply unit PSUH	
Supply voltage	230 V 50/60 Hz
Fuse	16 A
Dimensions w/d/h	330 x 355 x 225
Weight	20 kg
Protection class	IP 54

Lamp ignition sequence		
1.	Developing of ignition voltage	on power ON
2.	Warm up	ca. 45 seconds
3.	Restrict current consumption	while operating
4.	Reignition without cooling period	immediate

Drive unit FL51	
Rotation and tilt drive unit made of salt water-resistant cast aluminium with stainless steel grips to hold and operate the searchlight.	
Standby heater	
Power cable	3 m
Power consumption	280 W
Horizontal rotation	360°; 12,8°/s
Vertical tilt	+20°...-30°; 2,7°/s
Height of drive unit with search unit	ca. 968 mm
Base plate diameter	360 mm
Weight	29,8 kg
Protection Class	IP 56
Colour	RAL 9016

Drive unit FL20	
Rotation and tilt drive unit made of salt water-resistant cast aluminium with adapter plate to hold and operate the searchlight.	
Standby heater optional	
Power cable	3 m
Power consumption	50 W
Horizontal rotation	330°; 5°/s
Vertical tilt	+25°, 2,4°/s
Height of drive unit with search unit	ca. 736 mm
Base plate diameter	120 mm
Weight	13,8 kg
Protection Class	IP 67
Colour	RAL 9016

Control unit RCU-E	
Remote control with ON/OFF switch for searchlight and drive unit, position control switch (joystick) and indicator lamps for installation in a control panel.	
Front	120 x 200 mm
Height + Joystick	90 x 170 mm
Weight	2,1 kg
Protection class	IP 23

Control unit RCU-A	
Remote control with ON/OFF switch for searchlight and drive unit, position control switch (joystick) and indicator lamps for wall mount installation.	
Front	200 x 200 mm
Height + Joystick	80+ 85 mm
Weight	2,5 kg
Protection class	IP 23

3.3 Unit nameplates

Nameplate



- 1 Product designation
- 2 Product specification
- 3 Product serial number
- 4 Manufacturer

3.4 Dimensions

Searchlight with foot and on a column

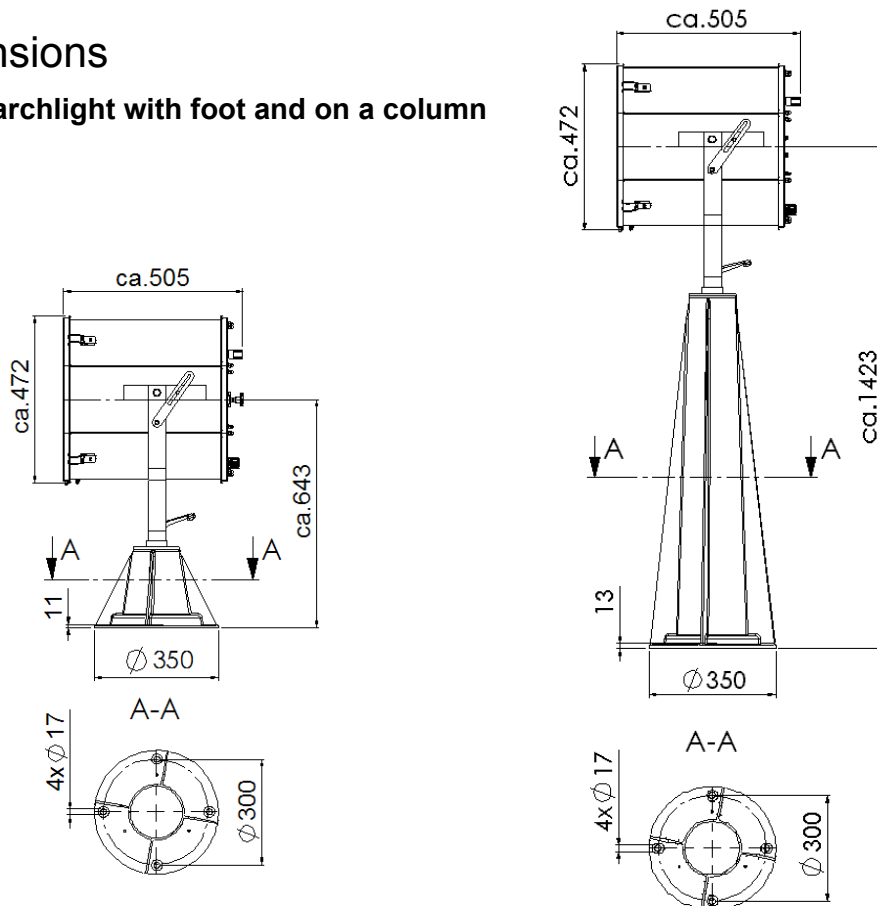

If the searchlight is equipped with the lamp focus adjustment its depth is about 511 mm instead of 505 mm.

Searchlight with foot and on a column with internal mechanical operation

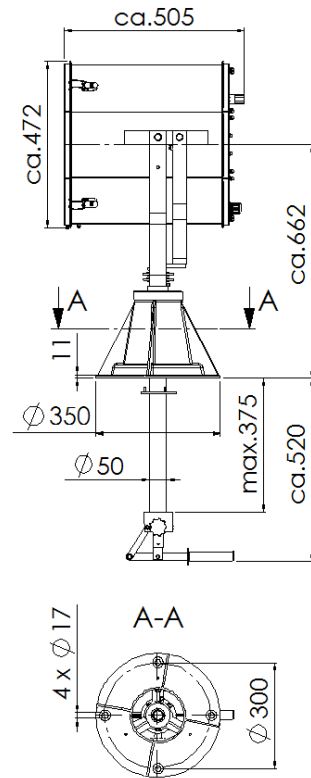

If the searchlight is equipped with the lamp focus adjustment its depth is about 511 mm instead of 505 mm.

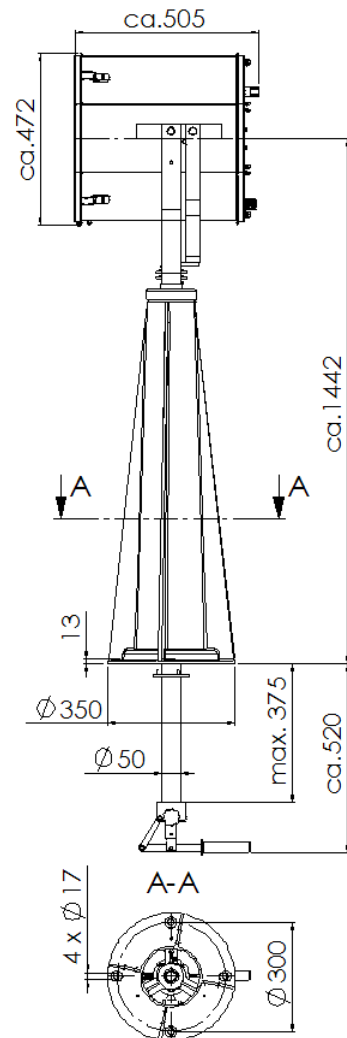

Searchlight with drive unit FL51 and FL20

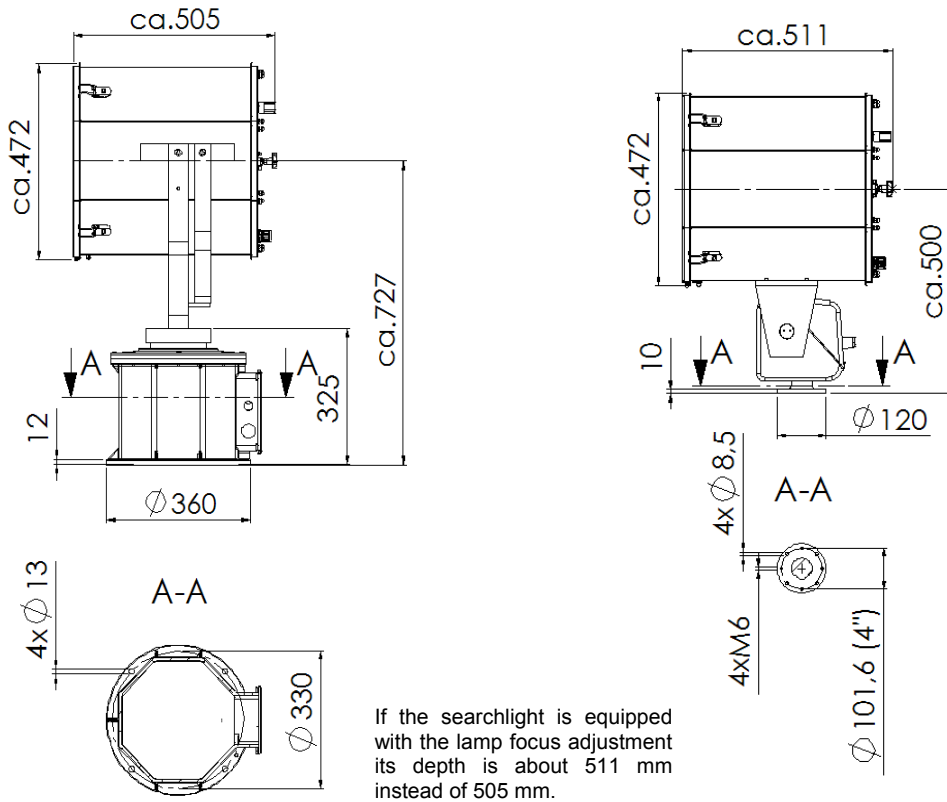

Remote control unit RCU

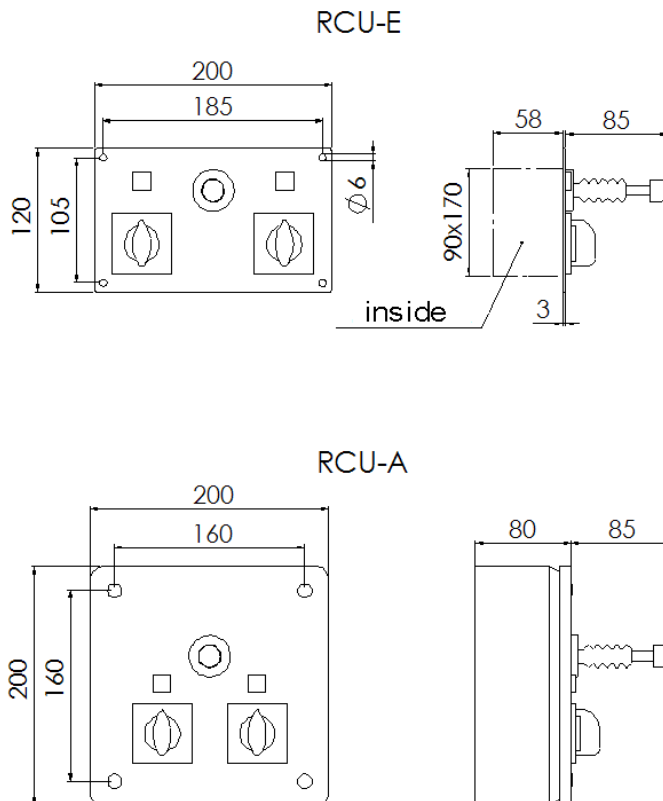

Power supply unit PSUH

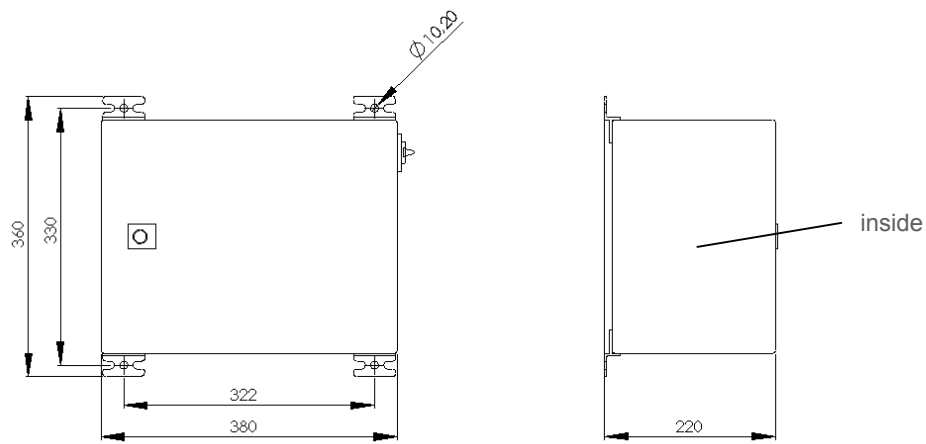

SH400-575 Rev.230903E

3.5 Circuit diagram

Principle diagram after drawing Nr.: W 03- 032 of 30.06.03

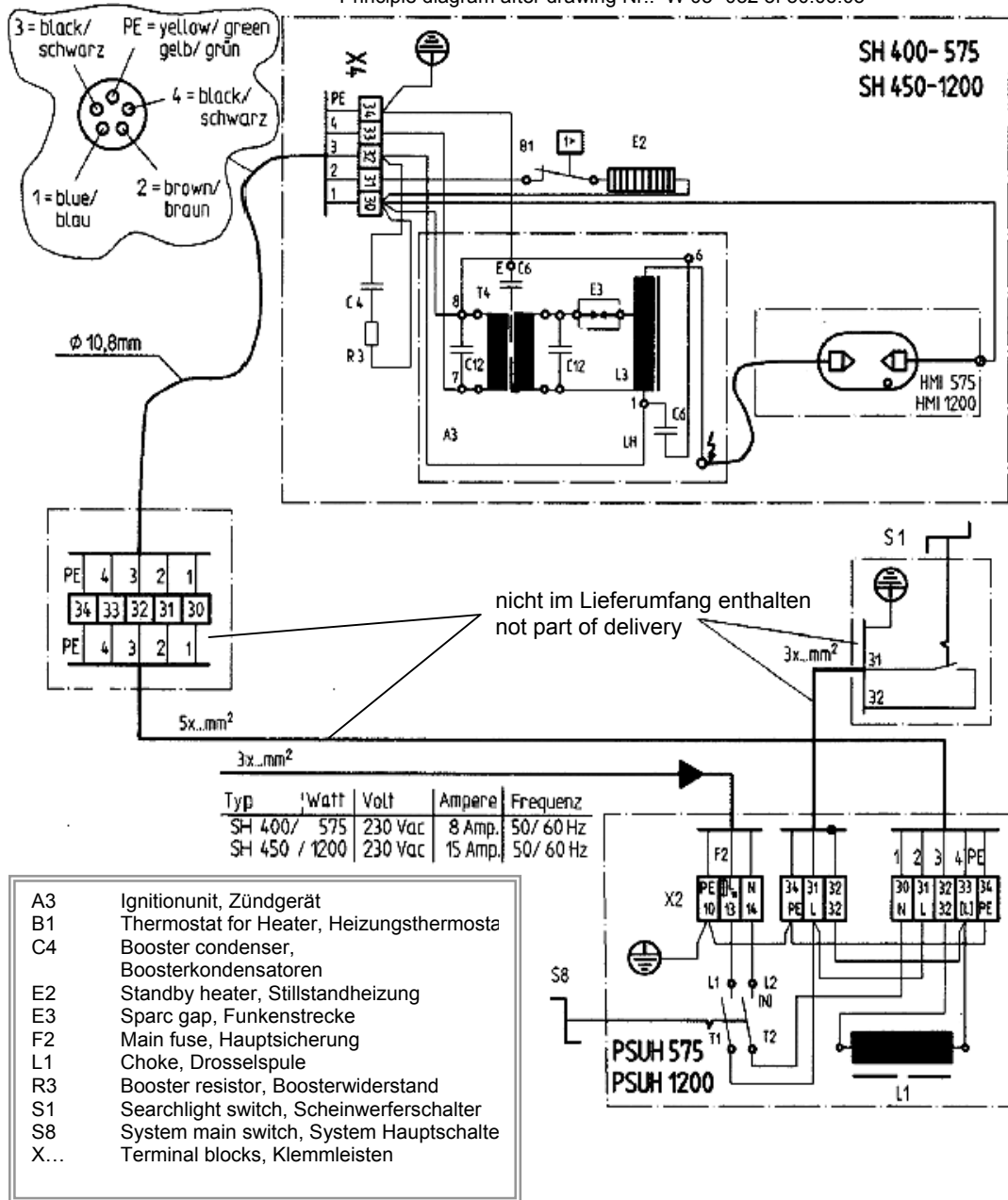

Warning! If the searchlight and the optional drive unit is switched off, the STANDBY-HEATER is still UNDER POWER !!!
 Bei abgeschaltetem Scheinwerfer und Getriebe steht die STILLSTANDHEIZUNG WEITER UNTER SPANNUNG !!!

Flexible cables should be used to connect SW.. and FL51.
 Zum Anschluss von SW.. und FL51 flexible Kabel benutzen.

SH400-575 Rev.230903E

Circuit diagram with drive unit and Remote control

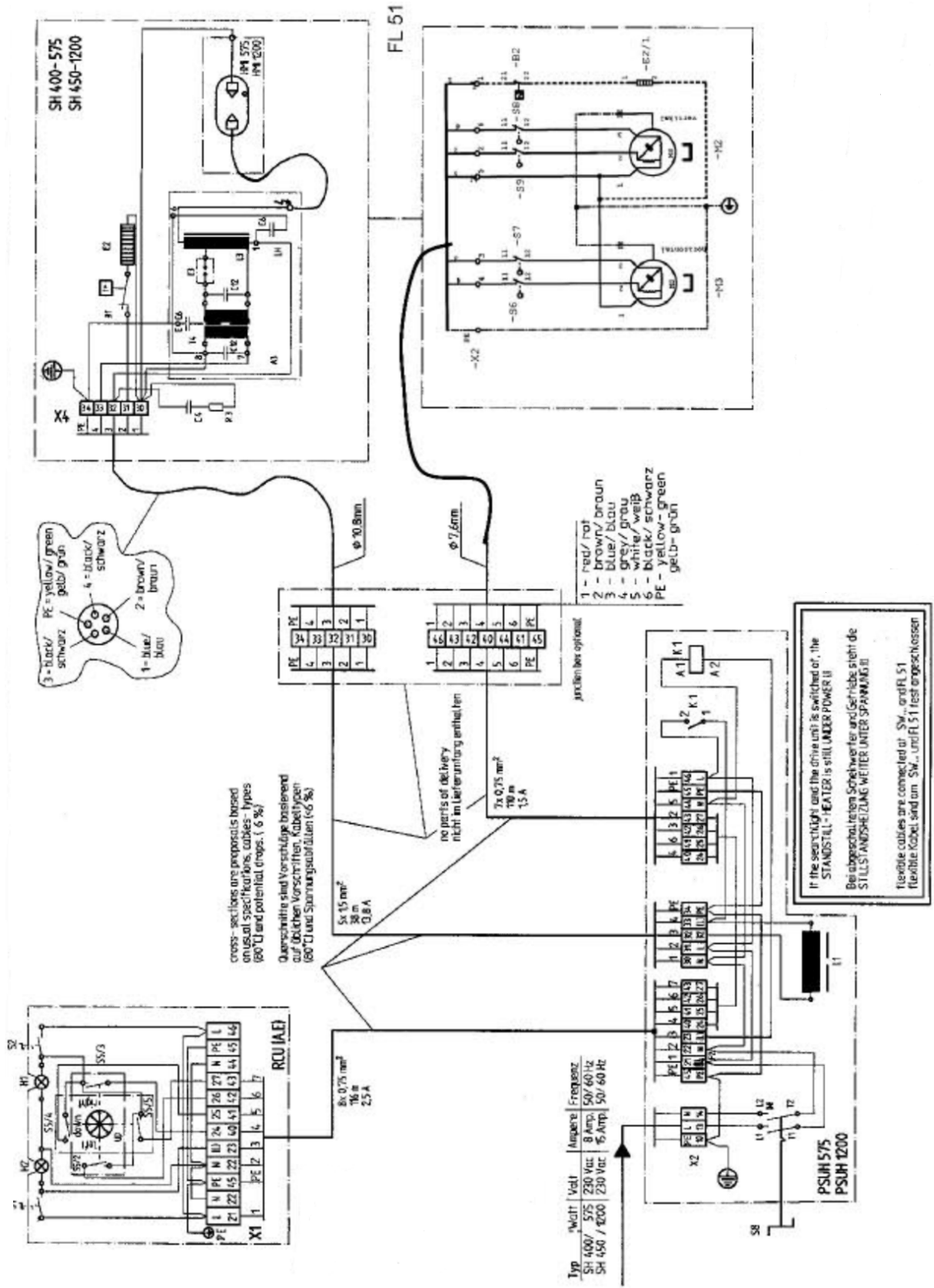

SH400-575 Rev.230903E

4. Installation

4.1 Unpacking the unit

Check that all parts have been included in the package. Do not operate the searchlight if there has been damage during transportation or parts are missing. Please contact your WISKA agent or our distribution partner in your country. You will find the address on the back of these operating instructions or go to www.wiska.de.

Remember to protect the environment and recycle the packaging.

4.2 Installation

Installing the searchlight with FL51 drive unit

If your searchlight was ordered with its electromechanical drive unit FL51 the searchlight comes pre-assembled on the FL51 drive unit.

At least two persons are required for installation due to the weight of the searchlight.

1. Drill four holes along a \varnothing 330 mm circle in diameter. For more information see chapter 3.4 *Dimensions*.
2. Place the drive unit at desired location and tighten screws.
3. Connect earth cable.

Installing the searchlight with FL20 drive unit

If your searchlight was ordered with its electromechanical drive unit FL20 the searchlight comes also pre-assembled with the FL20 drive unit.

At least two persons are required for installation due to the weight of the searchlight.

1. Drill four holes along a \varnothing 101,6 mm circle in diameter. For more information see chapter 3.4 *Dimensions*.
2. Place the drive unit at desired location and tighten screws.
3. Connect earth cable.

Installing the searchlight on a low base or a column

As an alternative, the searchlight can be mounted on a low base or a column.

At least two persons are required for installation due to the weight of the searchlight.

1. To mount it, four holes have to be drilled in a circle of \varnothing 300 mm in diameter, see chapter 3.4 *Dimensions*.
2. Place the drive unit at desired location and tighten screws.
3. Connect earth cable.

Installing on a low base or a column equipped with internal mechanical operation

As an option the configuration with low base or column can be equipped with an additional internal mechanical operation. The mechanical linkage runs in an internal pipe of the low base or column. Consequently the pipe must be brought down. To do so, an additional hole for the \varnothing 50 mm pipe has to be drilled in the middle of the \varnothing 300 mm circle.

See also chapter 3.4 *Dimensions*.

Installing the remote control unit RCU

If the searchlight is equipped with an electromechanical drive unit, a remote control unit is required also.

The control unit is available as panel mount unit RCU-E and as wall mount unit RCU-A. Electrically and functionally both units are identical.

To install the units drill the required holes and make opening if required as shown in chapter 3.4 *Dimensions*.

Be sure to provide wire of sufficient size (cross-section) for the cable length.

Installing the power supply unit PSUH

At least two persons are required for installation due to the weight of the PSUH.

Be sure to observe the instructions in chapter 2.4 *Operating requirements* on where to install the power supply unit.

The Power supply unit comes with four brackets for wall mounting.

The searchlight and the drive unit come with a 3 m power cable. If the PSUH is installed farther away from the searchlight, bear in mind that the supply voltage for the PSUH must be 230 V.

Installing the remote control unit RCU

If the searchlight is equipped with an electromechanical drive unit, a control unit is required also.

The control unit is available as panel mount unit RCU-E and as wall mount unit RCU-A. Electrically and functionally both units are identical.

To install the units drill the required holes and make opening if required, as shown in chapter 3.4 *Dimensions*.

Be sure to provide wire of sufficient size (cross-section) for the cable length.

4.3 Electrical connections



Danger of electrical shock! Electrical connections may only be completed by qualified personal. Be sure the power cord is dead and nobody can accidental resume the power supply during installation!

The circuit diagram is enclosed separately or you find it in chapter 3.5 *Diagram*.

Connected load values

Supply voltage: 230 V, 50/60 Hz.

Unit Fuse: 1 x 16A included.

Waterproof (IP56) installation of all cables

1. Unscrew the cover on the underside of the PSUH power supply unit and remove.
2. Drill holes matching the cable size and insert cable fittings into holes.
3. Feed cable through the cable fittings and fasten firmly.



Attention! To ensure that the protection class IP56 is maintained:

The cable sheathing must have a waterproof seal: pull the fittings firmly into place so that the seals are wrapped tightly around the cable fitting!

4. Connect cables in accordance with the circuit diagram (see separate circuit diagram or chapter 3.5 *Circuit diagram*).

Note: The cable from the searchlight and FL51 drive unit can be connected directly to the power supply unit (PSUH) or via a junction box.

Power supply

- Be sure to observe any applicable international or local country regulations! Connect to the power supply while ensuring reverse polarity protection!

Before first use:

- Check that installation has been carried out correctly. Wrong connections may destroy the searchlight unit as well as the Metal Halid lamp.
- Check to be sure that grounding and zero current works properly!
- Reinsert fuses.

5. Operation

Further on, operation will be described together with the electro-mechanical drive unit FL51 and its remote control unit RCU.

If your configuration is not equipped with such operating features you should have special attention to the following points:

- To direct the searchlight, only use the appropriate handles. Do not touch the housing of the searchlight during operation, - **Danger of burns!**
- Ensure that at power on and during operation nobody is in front of the searchlight, - **Danger of blinding!**
- Switch S1 to turn on the searchlight as described in chapter 5.2 is a separate switch in your configuration and is not located in the RCU. Because there is no electro-mechanical drive unit, switch S2 and the joystick are not available.
- Continue reading with chapter 5.2 *Turning on the searchlight.*

5.1 Control unit RCU

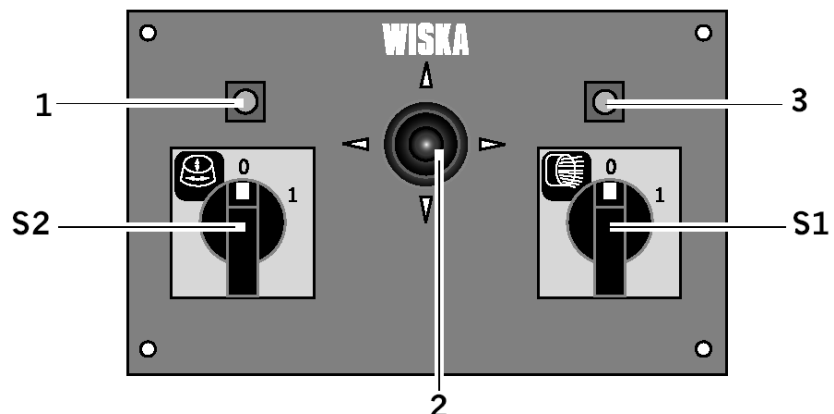

- 1 Drive unit indicator lamp
- S2 ON/OFF switch for drive unit
- 2 Joystick for drive unit
- S1 On/off Switch for Searchlight
- 3 Searchlight indicator lamp

5.2 Turning on the searchlight



Danger of burns! Never touch the searchlight during operation. The housing may reach temperatures as high as 180 °C. In case of burns, immediately cool the burned area and get medical aid.



Danger of blinding! Never look into the light source during operation. This poses a danger to your eyesight. Never point

the searchlight at people. Before you turn on the searchlight make sure that nobody is in front of the searchlight.

1. Turn the main power switch S8 on the PSUH power supply unit to position ON. This supplies power to the searchlights internal heating system and the heater of the optional drive unit.



Attention! If ambient temperatures are below 6°C, wait until housing interior has been heated to at least 6 °C before igniting the lamp.

Before you ignite the lamp make sure that all work has been completed and nobody is in front of the searchlight.

2. Turn on switch S1. The lamp will ignite
 3. In case you operate the searchlight by means of an electromechanical drive unit, you should turn it on with switch S2, which is also located on the RCU. The drive unit is now operational and can be controlled by means of the joystick on the RCU.
- If the lamp does not initiate or if it flashes a number of times, there is either insufficient ignition voltage for the lamp or the lamp is defective.

See chapter 7.3 *Changing the lamp* for more information on replacing the lamp.

5.3 Turning off the searchlight



Attention! To ensure operational readiness: only turn off the searchlight using the S1 and, if you work with an RCU, with the S2 switch on the control unit.

Do not turn off the S8 switch on the power supply unit because the internal heaters should stay on all the time.

6. Maintenance

6.1 Cleaning

Clean the front glass panel of the searchlight when required. When cleaning, check if the fasteners are firmly in place and check for rusting/corrosion.

No cleaning of searchlight interior is required. In the course of use, slight discoloration of the reflector surface will occur. This has no adverse effect on the unit and does not diminish the power of the lamp.



Danger of blinding! Make sure that nobody can turn on the searchlight while cleaning.

7. Replacing defective parts

7.1 Before you begin

1. Turn the main switch S8 to OFF.
2. Make sure the entire electrical system is dead and it can not be turned on accidentally.
3. Wait until the searchlight has cooled down.
4. Read the chapter 2.2 *Using Metal Halid lamps*
5. Be careful when handling the Metal Halid lamp and do not break it.

7.2 Construction overview

The following figure should help to understand the assembly of the searchlight before you begin with replacement work. To do the actual replacement work follow the instructions on the following pages!

Construction

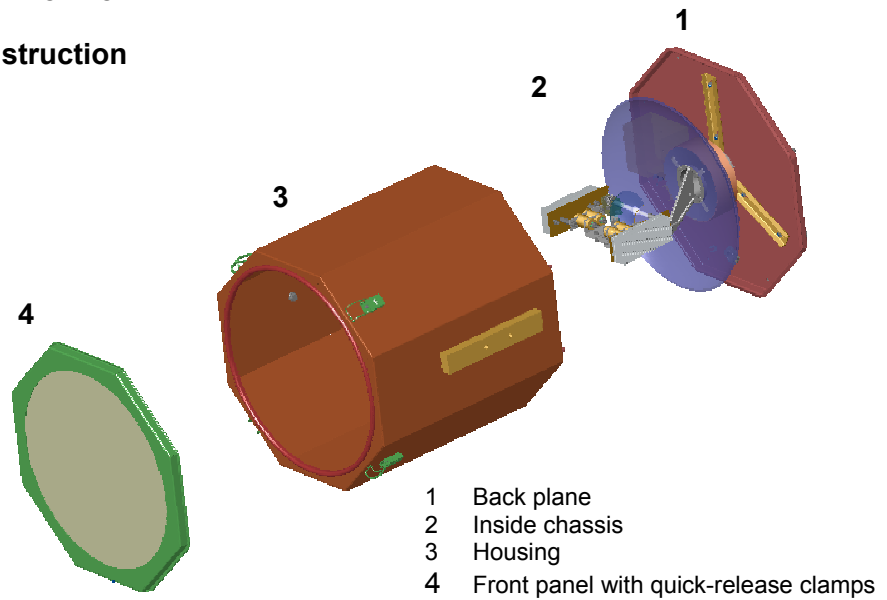

Inside chassis

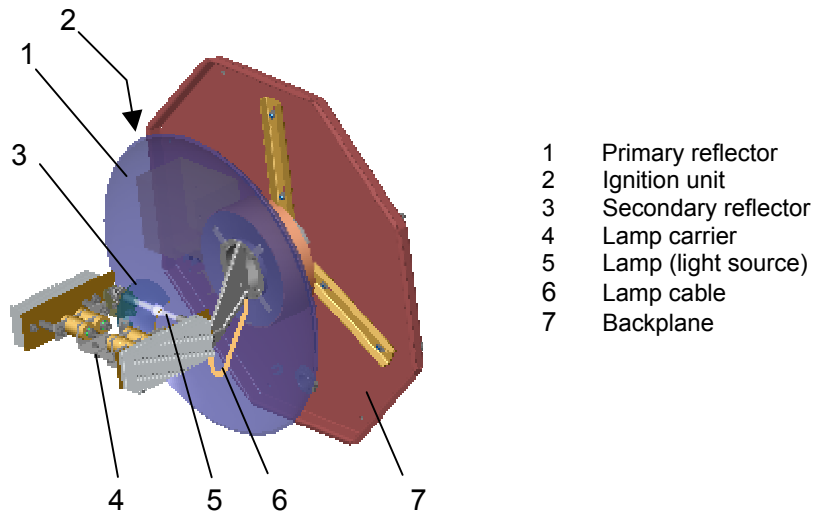

All functional components are assembled on the inside chassis and the backplane. The inside chassis is mounted to the backplane and can be taken out of the housing together with the backplane.

7.3 Changing the lamp

The lamp is defective if it

- only flashes a number of times without lighting up
- the lamp electrodes have burned out
- if the glass body is blackened.

Be sure to also replace the lamp if its average service life of 750 hours has been exceeded.



Danger! Any personnel carrying out repairs and maintenance must have been properly instructed by a qualified specialist about the dangers and required safety precautions!

Be sure to read chapter 7.1 *Before you begin*.

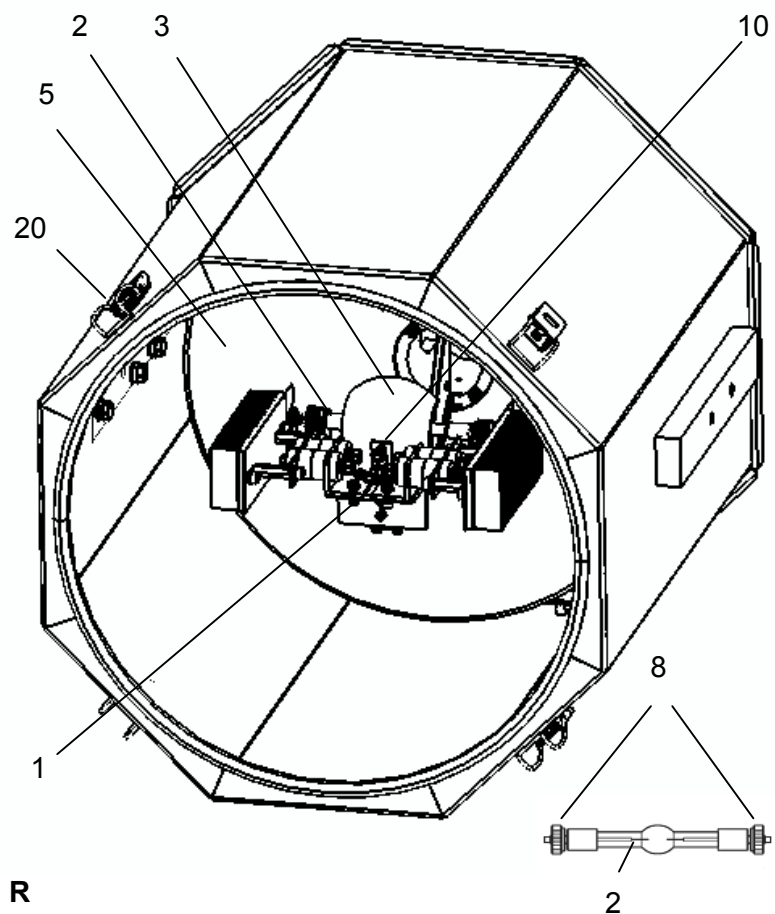

Removal:

1. Loosen the quick-release clamps **20**, carefully remove front plane and place safely out of the way.

Note: The lamp **2** is installed in the lamp carrier **1** horizontally and is partly hidden by the secondary reflector **3**. You can see the lamp in the primary reflector **5** and observe removal and installation in this mirror.

2. Loosen screws **8** of the defective lamp until you can lift it

from its position in the lamp socket without force.

3. Put away the defective lamp without breaking it.



Attention! Should the lamp have been broken for any reason, follow the guidelines described under 2.3 *When a lamp breaks* for the sake of your personal health and the environment.

Installation:

Attention! Before installing in the new lamp, check it for any fingerprint marks or damage as such as scratches and cracking. Do not use the lamp if there are any signs of damage. Remove any fingerprint smudges using a non-abrasive, lint-free cloth and alcohol solution.

1. Open the protective shroud of the new lamp. Be careful not to touch the glass with your fingers. When you handle the lamp use one-way gloves to avoid fingerprints.
2. Loosen the screws **8** far enough so you can insert the lamp in the lamp socket **1**.
3. Put the lamp in the slot of the lamp socket **1** to its rest.
4. Tighten the screws **8** in this lamp position.
5. Put the front panel back in place and close the quick-release clamps.
6. The defective lamp must be disposed in the proper way following the rules described in chapter 2.2 *How to use Metal Halid lamps*.

7.4 Changing the primary reflector

Danger! This repair work must be completed by a qualified electrical technician!

Be sure to read chapter 7.1 *Before you begin* first.

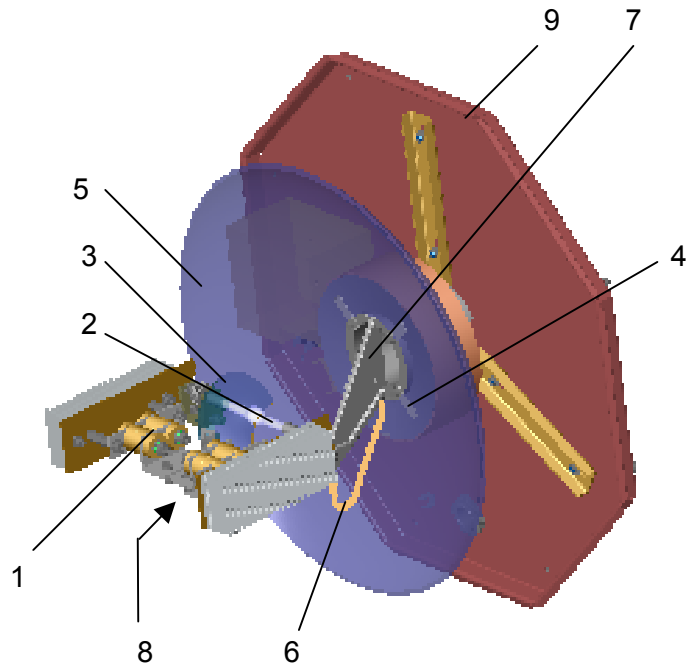

Removal:

1. Loosen the screws on the back of the searchlight and take out the back plane **9** together with the inside chassis.
2. Disconnect the external cable to get the assembly free.
3. Place the assembly on a safe and clean work surface.
4. Take out the lamp **2** and store it in a safe place. See chapter 7.3 *Changing the lamp*.
5. Disconnect the two lamp cables **6** from the lamp carrier **1**.
6. Loosen the two screws **8** underneath the lamp carrier, which hold the lamp carrier **1** on its support **7** and take off the lamp carrier.
7. Take off the whole lamp carrier assembly and place it out of the way.
8. Loosen the leaf springs **4** on the reflector **5**.
9. Cut open silicone seam on the back with a knife and remove the reflector **5** from its retaining ring.

Installation:

Attention! Only use degassed silicone gel. Vapour from silicone which has not been degassed will collect on the lamp and destroy it.

1. Glue the new reflector onto the retaining ring using silicone gel. Allow to dry for one day!
2. Place the reflector onto its support and re-fasten using the leaf springs **4**.
3. Check that the reflector is properly seated.
4. Take the lamp carrier and screw it back on to its support. Be careful not to damage the new reflector!
5. Reconnect the lamp cables **6** to the lamp carrier, don't forget the washers.
6. Reinstall the lamp to the lamp carrier, see chapter 7.3 *Changing the lamp*.
7. Reconnect the external power cable.
8. Push the assembly of back plane and inside chassis back into the searchlight housing and screw the back plane on to it.

7.5 Replacing the secondary reflector



Danger! This repair work must be completed by a qualified electrical technician!

Be sure to read chapter 7.1 *Before you begin*.

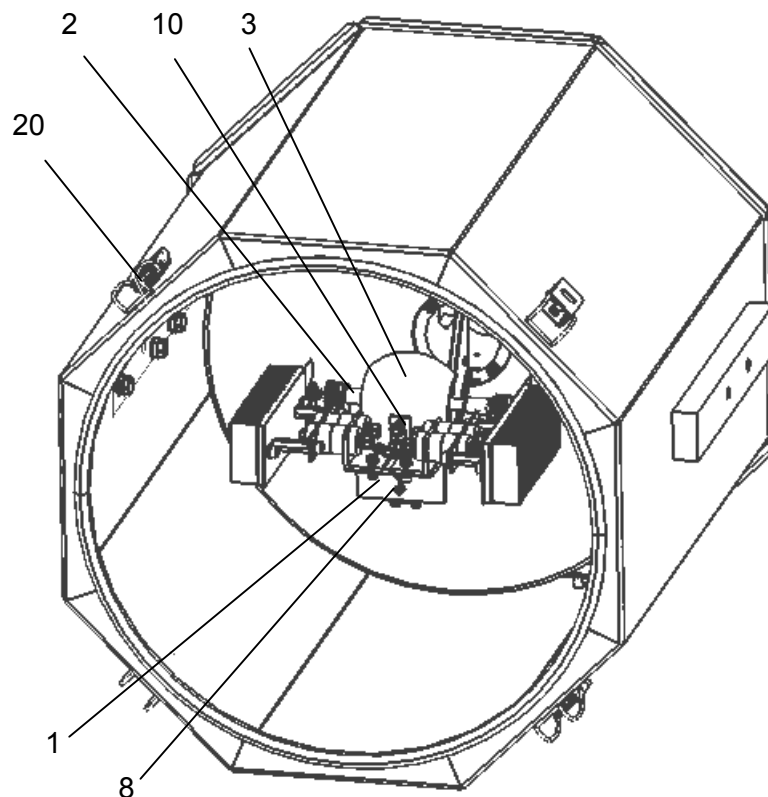

Removal:

1. Loosen the quick release clamps **20** of the front plane and put it away.
2. Take out the lamp, see chapter 7.3 *Changing the lamp*.
3. The secondary reflector **3** is fastened to the lamp carrier **1** with a single screw **10**. Unscrew the secondary reflector and take it out.

Installation:

1. Place the new reflector to its position on the lamp carrier. Fasten it with screw **10**.
2. Reinstall the lamp, see chapter 7.3 *Changing the lamp*.
3. Put back the front plane and fasten it with the quick release clamps.

7.6 Replacing the ignition unit



Danger! This repair work must be completed by a qualified electrical technician!

Be sure to read chapter 7.1 *Before you begin*.

Removal:

1. Loosen the 8 screws which hold the back plane.
2. Take out the inside chassis with the back plane from the searchlight housing.
3. Take out the lamp and keep it on a safe place.
4. The ignition unit is mounted on the back plane. To disconnect the cables you have to disassemble the unit from the back plane first. Loosen the three screws which hold the ignition unit on its stand-offs.
5. To pull off the ignition unit from its position you have to loosen one of the lamp cables on the lamp carrier and the cable which connects to the thermostat.
6. Now, pull out the ignition unit to a more convenient position and disconnect all cables from it. Make sure you can reconnect them to the new ignition unit correctly, see chapter 3.4 *Circuit diagram*.

Installation:

1. Take the new ignition unit and connect all cables, see chapter 3.4 *Circuit diagram*.
2. Place the new ignition unit on its stand-offs and screw it tight.
3. Reconnect the lamp cable on the lamp carrier and the cable to the thermostat.
4. Reinstall the lamp.
5. Close the back plane.

8. Disposal

Electrical parts contain toxic substances. Be sure to dispose these components properly or send defective parts to WISKA. The mailing address is found on the back cover of these operating instructions.

Special care must be taken to dispose the Metal Halid lamps. Read chapter 2.2 *How to use Metal Halid lamps*.



Risk of Health

Metal Halid lamps may not be destroyed in any case. Read chapter 2.3 *In case a lamp breaks*.

9. Spare parts

Searchlight head SH400

Designation	Art. No.
Front frame + front glass	77815
Primary reflector	87080
Silicone gel	88019
Secondary reflector	87784
Metal Halid lamps 575 W	87504
SH400 lamp carrier	77285
Ignition unit type 210	87770
Standby heating unit	87276
Thermostat for standby heating unit	82174

Power supply unit PSUH

Designation	Art. No.
Choke for 575W lamp	87794
Fuse 16 A	87782

Remote control unit RCU

Designation	Art. No.
Position control switch (XD2-GE3)	87342
ON/ OFF Switch	87341
Lamp on indicator	87494

Drive unit FL51

Designation	Art. No.
FL51 bearing kit	21015
FL51 Z hub kit	21016
Motor bearing kit	21017
Motor Z hub kit	21018
O-ring housing	85598
O-ring bearing	89013
Drive unit seal	89021
Cover for terminal box	77892

Drive unit FL20

Designation	Art. No.
Tilt Motor Kit 230VAC	21581
Pan Motor Kit 230VAC	21582

All other parts should only be ordered after consulting with WISKA sales staff.

WISKA Hoppmann & Mulsow GmbH

Kisdorfer Weg 28 • D-24568 Kaltenkirchen
Tel. +49 (0) 4191/508-100 • Fax +49 (0) 4191/508-249

Internet www.wiska.de • E-Mail wiska@wiska.de

Please locate a Wiska representative for your country by visiting our web-site.

