

Instruction Manual

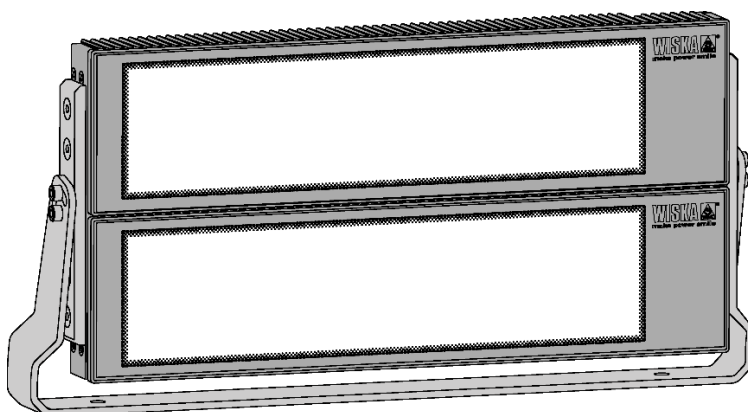

LED Floodlight 5010

5010-1x220, 5010-2x220

Keep the instruction manual always handy.

Table of contents

1.	INTRODUCTORY REMARKS	3
2.	SAFETY INSTRUCTIONS	3
3.	DESCRIPTION AND INTENDED USE	5
4.	OPERATION	6
5.	MALFUNCTIONS DURING OPERATION	6
6.	CLEANING	6
7.	REGULAR REVIEW	7
8.	DISPOSAL AND DECOMMISSIONING	7
9.	TRANSPORT AND STORAGE	8
10.	MOUNTING AND ELECTRICAL CONNECTION	8
11.	COMMISSIONING	12
12.	MAINTENANCE AND REPAIR	13
13.	TECHNICAL DATA	15
14.	ACCESSORIES/SPARE PARTS	19
15.	DECLARATION OF CONFORMITY/CERTIFICATE	20

1. Introductory remarks

These operating instructions are intended for the operator, his personnel, and the installer. The instructions help correctly install Floodlight 5010 and use it safely in accordance with its intended purpose.







These instructions contain important information on the installation and operation of the floodlight. By following the given steps, hazards are avoided, repair costs and downtimes are reduced, and reliability and service life are increased.

Read the operating instructions carefully and attentively! WISKA Hoppmann GmbH is not liable for any damages or malfunctions resulting from the non-observance of these operating instructions.

2. Safety instructions

The operator bears the responsibility to use the product as described in the intended use.

A warning indicates dangerous situations to be avoided, followed by an explanation of the situation. The symbols and safety instructions used are as follows:

Icon	Signal word	Meaning
	DANGER	Probable result: Immediate death or serious injury
	WARNING	Possible result: death or serious injury
	CAUTION	Possible result: Slight to moderate injury to persons
	ATTENTION	Possible consequences: Material damage and malfunctions
	Electrician	Installation and repairs may only be carried out by a qualified electrician / electrical skilled person
	Electrical voltage	Injury due to open live parts and components
	Unlocking	Switch off the power before starting work and secure it against being switched on again

2.1 General safety instructions



Installation, commissioning, and maintenance should only be carried out by a qualified electrician.

Use Floodlight 5010/ Power Supply unit 5010-PU based on its IP protection class; otherwise, it may get damaged.

Avoid dropping or jolting the floodlight, as it could get damaged.

The tightening torques specified by the manufacturer must be observed.

Allow the LED module to cool for at least five minutes before replacing it.

⚠ WARNING: The Floodlight 5010 and the Power Supply unit 5010-PU should only be opened or repaired by an authorized electrician.

⚠ CAUTION: Switch off Floodlight 5010 and disconnect the Power supply unit from the power source immediately if smoke, sparks, or fumes are emitted, or an unusual odor is detected.

2.2 Electrical voltage

Read this manual carefully. If applicable, also consider the operating instructions of other manufacturers.

Install Floodlight 5010 / Power Supply unit 5010-PU as described in this manual.

ATTENTION: Electrical connections and connection cables must comply with all relevant regulations.

Observe the safety regulations for electricians: Before starting any installation or maintenance work, disconnect the power supply, secure it from being switched on again, check that no voltage is present, earth and short-circuit and cover adjacent live parts.

⚠ WARNING: Floodlights must not be installed outdoors in rainy weather due to the danger of an electric shock.

⚠ CAUTION: Observe the load limits of extension cables and sockets to avoid the risk of fire or an electric shock.

⚠ WARNING: Never repair damaged power cables! This poses a danger to life. Disconnect the Floodlight from the mains and have it repaired.

All cables and accessories must be professionally installed to function reliably.

Consider the national and local installation requirements and classification rules. In some countries, lighting may only be installed by registered installers.

Clamping screws in electrical connections must be tightened as specified by the manufacturer.

Observe the symbols for connecting the cables in accordance with national directives:

N = Neutral L = Phase  = Earth LS = Live, switched.

2.3 These instructions apply to the following versions:

Floodlights 5010 1x220 or 5010 2x220, as either narrow, normal, or wide beam version, and Power Supply unit 5010-PU powered by AC mains.

2.4 Change history

Version	Revision date
1.0	02/2025

2.5 Original instructions

The German version of this document is the original manual.

3. Description and intended use

The Floodlight 5010 is used to illuminate surfaces in and on ships. The floodlight can be used within a DALI-System. The Floodlight 5010 is available in different versions, with either one or two modules, narrow beam or medium beam or wide beam angle. It is used for fixed installations and comes with an external power supply unit for 230V AC. It consists of one or two LED module(s) in a metallic housing, a stainless-steel mounting bracket, a connection box, a cable, and for the two-module version a joint bracket. The Floodlight 5010 meets the IP66/67 degree of protection.

Front view floodlight

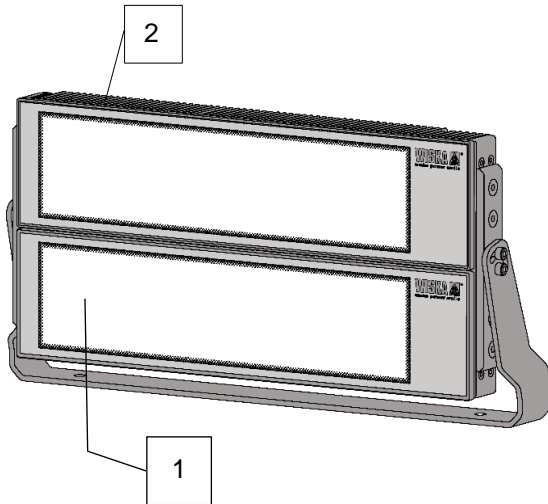

Rear view

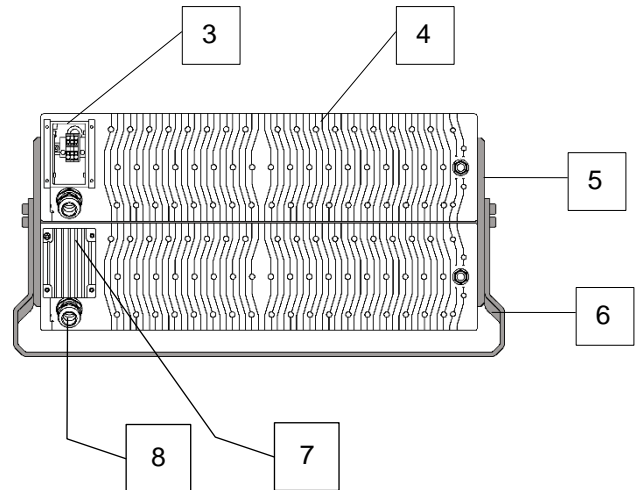

Power Supply unit 5010-PU

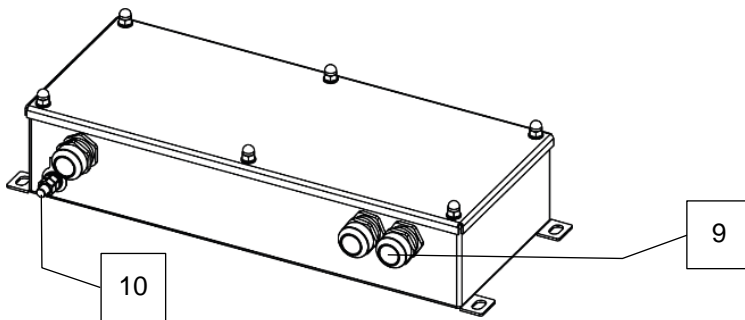

Illustration 1 - Floodlight 5010 with 2 modules and power supply unit

Pos.	Designation	Pos.	Designation
1	LED module	2	Case
3	Terminal box (1 per module)	4	Cooling fins
5	Joint bracket (only 5010-2)	6	Mounting bracket
7	Terminal box cover	8	Cable gland (floodlight)
9	Cable gland (5010-PU)	10	Earthing bolt

Floodlight 5010 is designed to illuminate surfaces on ships. Its usage is forbidden in the following scenarios:

- Using the floodlight to dazzle people or interfere with shipping traffic.
- Using the floodlight as a handle.
- Hanging objects from the cable or holding on to the cable.

4. Operation

The floodlight is operated using the light switch installed on-site in the electrical supply line or by an external control system such as DALI.

If the product is not to be used for longer, no preparation is required.

A visual inspection before recommissioning is recommended.

5. Malfunctions during operation

Repairs and maintenance must only be performed by skilled personnel with proven qualifications.

In case of malfunctions, first consider the measures listed below:

Problem	Cause	Remedy
Light cannot be switched on	Power supply is interrupted	Re-establish the power supply: Switch/ connection.
	Light switch is defective	Ask the electrician to replace the light switch.
	Module is defective	Ask the electrician to replace the LED module.
	Fuse failed/is short	Eliminate the error and then switch on the fuse.
	Floodlight is incorrectly connected	Ask the electrician to check the connection.
	Connection cable is defective	Ask the electrician to replace the connection cable or LED module.
	Incorrectly installed cables	Ask the electrician to change the installation
Water in the LED module	Ventilation is defective	Ask the electrician to replace the LED module.
	Housing is broken	
	Washer is leaking	
Incorrect illumination	Floodlight suspension needs adjusting	Realign the floodlight and retighten the screws.
One LED module does not work	LED module is defective	Ask the electrician to replace the LED module. Individual LEDs cannot be exchanged.
Light flickers	A dimmer is connected	Ask the electrician to remove the dimmer.
	Malfunction in the electrical system	Inform the electrician.

6. Cleaning

Clean the outer surfaces of the floodlight with a soft, dry cloth. In case of heavy soiling, slightly moisten the cloth with clear water.



WARNING

Risk of electric shock!

→ Before cleaning, switch off the floodlight / disconnect it from voltage sources.

ATTENTION

Do not use solvents, petrol, or alcohol while cleaning. Further, do not use sharp-edged tools, screwdrivers, metal brushes, or the like. They can damage the surfaces of the floodlight.

7. Regular review

The floodlight is maintenance-free. In case of problems or malfunctions, please refer to the chapters “Troubleshooting” and “Maintenance.”

Perform visual and functional tests at regular intervals—at least once a month.

The examination should include the following:

- A visual inspection for damage and heavy soiling of the case.
- A visual inspection for damage or rust on the retaining bracket and fixing screws.
- A visual inspection for damage to the cables.
- A visual inspection for damage and contamination to the protective glass.
- A visual inspection for the formation of condensed water inside the LED module.
- A function test of the light source.
- A function test of the retaining bracket.
- A test for noises (crackling, humming) and heated supply lines.



WARNING

Danger of glare!

The light intensity can permanently damage the eyes if the floodlight is switched on during maintenance work. People can become disoriented and fall down.

- Before maintenance, switch off the light and secure the product from being switched on again.

8. Disposal and decommissioning

Comply with the local and national laws, guidelines, and regulations regarding the disposal of materials and products.

Waste Electrical and Electronic Equipment (applicable in the European Union and other European countries with separate collection systems.)

The electrical appliances by WISKA Hoppmann GmbH are professional electrical appliances, which are also called business-to-business (B2B) appliances. We take back old electrical appliances in accordance with the national WEEE law (i.e., in Germany § 19 ElektroG) and dispose of them properly. Please contact us before shipping your old WISKA electrical appliances at contact@wiska.de. Components, such as cable glands, do not fall under this law.

Do not mix or dispose of old electrical equipment from WISKA Hoppmann GmbH with other commercial waste.

WISKA LED lamps must not be disposed of in commercial or household waste, because over 90% of the components of old lamps can be recycled. LED lamps are to be recycled via a collection point or via municipal recycling centers. This also applies to our lamps sold to B2B customers.

9. Transport and storage

Transport and storage only permitted in original packaging.

10. Mounting and electrical connection

Note:

Each module must be electrically connected to the power supply unit.

Installation, commissioning, maintenance, and repair should exclusively be carried out by skilled personnel with proven qualifications.



DANGER

Danger to life from electric currents

Working on open circuits can result in short circuits and body shorts.

- An electrician should be present when working on electrical components.
- Make sure that the system is disconnected from the electrical connection.
- Secure the power supply against being switched on again.
- Cover open external plant components.
- If necessary, short-circuit the system components.
- Test whether the system is voltage-free.

10.1 Preparation

Required tools	Screwdriver, open-end wrench, ratchet
Required materials	Screws/bolts suitable for the load and ambient conditions
1	<p>Mark the mounting positions.</p> <p>ATTENTION: Malfunctions due to constantly dripping water are possible. Do not install floodlights under drip edges or rain gutters. Maintain a minimum distance of 30 cm from a drip edge.</p>
2	<p>Prepare mounting points for installation of luminaire.</p>

3 Prepare mounting points for installation of power supply.

10.2 Mounting

Required tools	Screwdriver, open-end wrench, ratchet lever
----------------	---

4 Fix the floodlight with screws or bolts to the wall or to the ceiling.
Hint: If fixing to a pole or railing use with an additional railing bracket.

5 Fix the power supply unit with screws or bolts to the wall or to the ceiling.

10.3 Electrical Connection

See 13.5 Electrical diagram for specifications

Prepare the following cables:

- 1x Connection 5010-PU to floodlight (3 wires DC +/-, PE, optionally DALI +/-, max. 4 mm², cable 9-17 mm)
- 1x Power supply to 5010-PU (3 wires L/N/PE, max. 4 mm², 220-240V 50/60 Hz)
- Optional: DALI (xxx 2 wires +/-, max. 4 mm²)

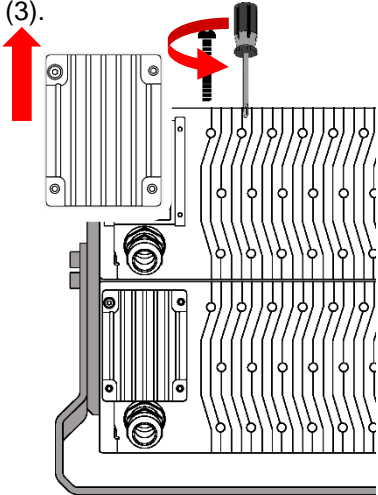
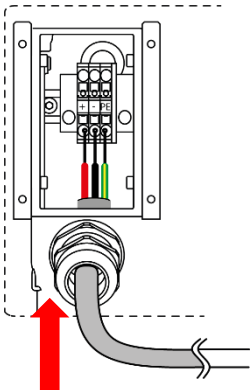
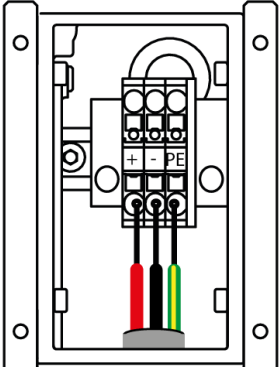
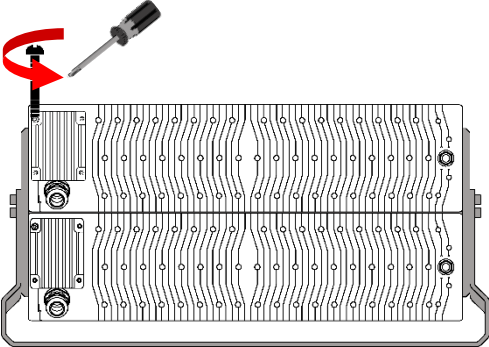
Required tools	Screwdriver, open-end wrench, ratchet lever
<p>1 Unscrew and lift the terminal box cover (7) of each 5010 module's terminal box (3).</p> 	<p>2 Insert the cables into the terminal boxes (3).</p> 
<p>3 Lay on the wires (power supply DC +/- , PE)</p> <p>Hint: Always observe the labeling on the terminal block.</p> 	<p>4 Attach the terminal box cover (7). Close the terminal box (3). Fasten the 4 cover screws of each module.</p> 

Connect the power supply unit

5 Unscrew and lift the cover of 5010-PU.

(6x)

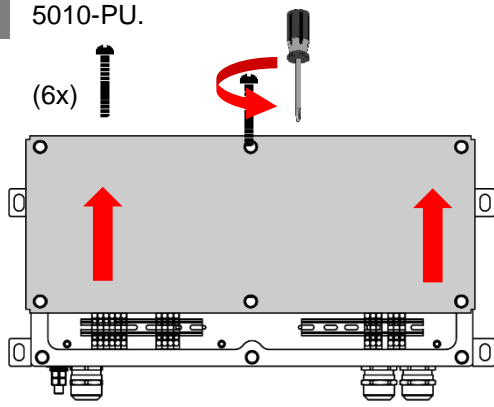

6 Loosen the cap nut on the cable gland and feed the required cables through. Then tighten the cap nut again.

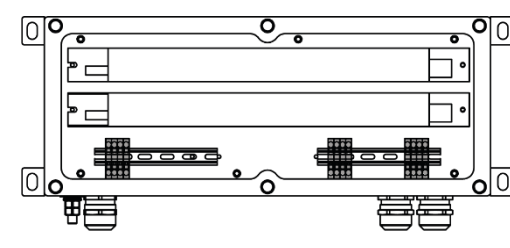

i The tightening torque for the cable gland should be **10 Nm!**

Depending on the model connect either the wires of the 1-module floodlight (7a):

7a Terminal blocks with push-in connectors. Wire it up. Use Phase (L), Neutral (N), and Protective Earth (PE) conductors for AC power supply. Wire up power supply to modules (DC +/- and PE). Plug-in terminals arrangement may vary. Observe the approval drawing for connection.

AC power-in (optional) DALI

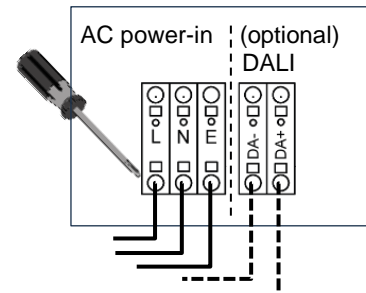

DC power-out floodlight

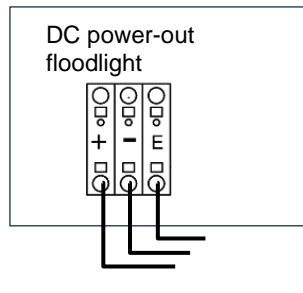

Brown = L
 Blue = N
 Yellow/ green = PE

Hint:
 Always observe the labeling on the terminal block.

Or connect the wires of the 2-modules floodlight (7b):

7b Wire it up. Use Phase (L), Neutral (N), and Protective Earth (PE) conductors for AC power supply. Wire up power supply to modules (DC +/- and PE). Plug-in terminals arrangement may vary. Observe the approval drawing for connection.

AC power-in (optional) DALI

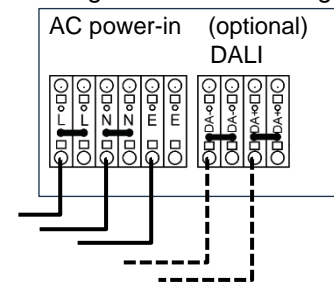

DC power-out floodlight

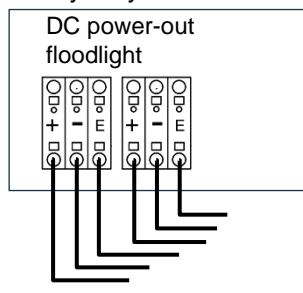

Brown = L
 Blue = N
 Yellow/ green = PE

Hint:
 Always observe the labeling on the terminal block.

Finish the connection:

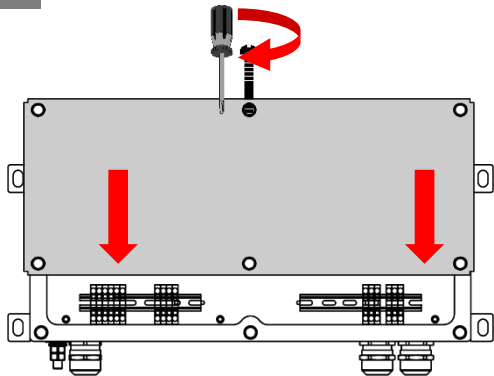
<p>8 Close the cover. Fasten the 6 cover screws.</p>  <p>i The tightening torque should be 8 Nm!</p>	<p>9 The floodlight is ready for comissioning</p> <p style="text-align: center;">✓</p>
--	---

11. Commissioning

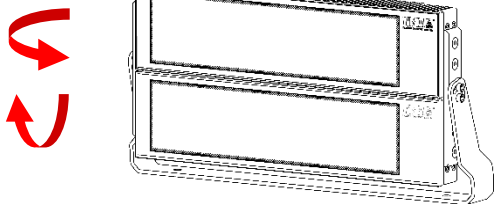
Required tools	Allen Screwdriver	
<p>1 Align the floodlight with the surface to be illuminated.</p>		
<p>2 Firmly tighten the screws of the bracket.</p>	<p>i Tightening torque: 20 Nm</p>	
<p>3 Check the floodlight's functioning.</p>	<p>4 ✓</p>	

12. Maintenance and repair

DANGER



Danger to life from electric currents.

Working on open circuits can lead to short circuits and body short circuits.



An electrician should be present when working on electrical components.



- Make sure that the system is disconnected from the electrical connection.
- Secure the power supply against being switched on again.
- Cover open external plant components.
- If necessary, short-circuit the system components.
- Test whether the system is voltage-free.

12.1 Replacement of a module





DANGER of electric shock

Disconnect the floodlight from the power supply.

Observe safety measures to prevent reconnection.

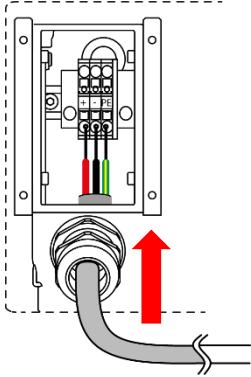
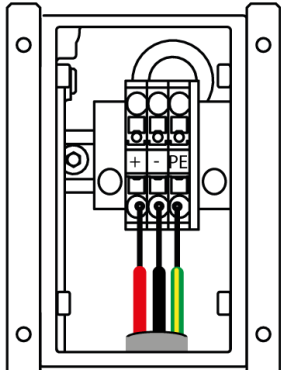
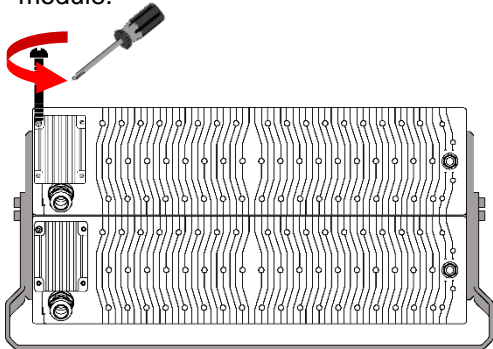
Required tools: Allen screwdriver, slotted screwdriver, hex wrench	
<p>1a 1-module version only: Unscrew the 4 Allen screws at the module frame. Then pull the module out of the bracket. Re-use the screws for the new module.</p>	<p>1b 2-module version only (upper/lower module): Unscrew the 4 Allen screws at the joint bracket. Pull the module out of the bracket. Re-use the screws.</p>
<p>2 Insert the new module and re-tighten the 4 screws. Tightening torque: 20 Nm.</p>	<p>3 Unscrew and lift the terminal box cover (7) of each 5010 module's terminal box (3).</p>

<p>4 Insert the cables into the terminal boxes (3).</p> 	<p>5 Connect each cable (power supply DC +/- , PE)</p> 
<p>6 Attach the terminal box cover (7) to close the terminal box (3). Fasten the 4 cover screws at each module.</p> 	<p>7</p> 

13. Technical data

Specification	MB	NB	WB
Illuminant type	LED		
Luminous flux	30.000 lm per module		
Light color	5700 K		
Power per Module	220 W		
Lens	Medium beam	Narrow beam	Wide beam
Material	Aluminium, stainless steel		
Cable gland	1 per module M25 (key width SW 29 mm)		
Colour	White or black module (RAL9016 or RAL9005)		
Degree of protection	IP66/67		
Mounting	Wall		
Rated lifetime	L80/B10 @Ta +45° C		
System Lifetime	100000 h (floodlight and power supply)		

5010-PU power supply

Operating voltage	220 – 240 V AC (50/60 Hz) / 220 – 240 V DC
Connectivity	DALI-D4i
Cable gland	3 x M25 (key width SW 29 mm)
Colour	RAL9015

13.1 Dimensions (mm)

Version	Outer dimensions			Weight
	W	H	D	
	mm	mm	mm	kg
5010 – 1x220	620	185	94	6.4
5010 – 2x220	640	315	108	12.8
5010 –PU	440	160	90	4.7 / 5.3**

Including the mounting bracket

** for 1 module/ for 2 modules

Version	Outer dimensions			Weight
	W	H	D	
	inch	inch	inch	lb
5010 – 1x220	24.4	7.3	3.7	14.1
5010 – 2x220	25.2	12.4	4.3	28.2
5010 –PU	17.3	6.3	3.5	10.4 / 11.7**

13.2 Dimensional drawings

5010-1x220 with one module	5010-2x220 with two modules
5010-PU	

13.3 Product identification



Floodlight 5010 nameplate (example)



Power Supply 5010-PU nameplate (example).

The type label has a three-row design and includes the following:

Pos.	Designation
1	Article short text
2	Performance data
3	Power consumption
4	Country of origin
5	Serial number
6	Notified Body
7	Identification index

13.4 Scope of delivery

The floodlight is mainly custom-made.

1 Power supply unit

Either 1 module + bracket or 2 modules + bracket + joint bracket

It optionally features either narrow, medium, or wide beam lens(es).

Further options are available based on the order, such as colour.

Note: All connection cable to both 5010-PU and LED floodlight 5010 are to be provided by the installer.

13.5 Electrical diagram

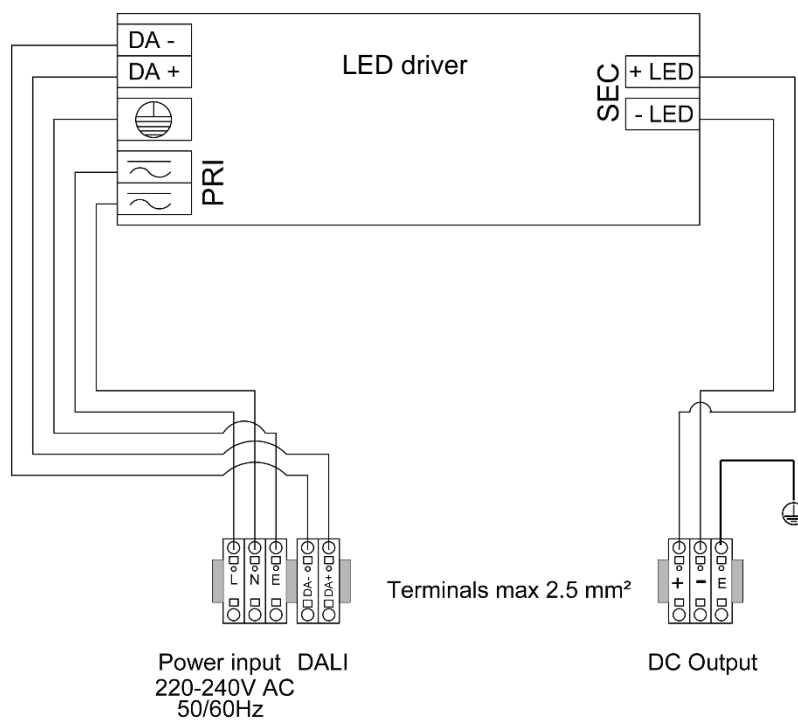

Floodlight 5010: 1 module

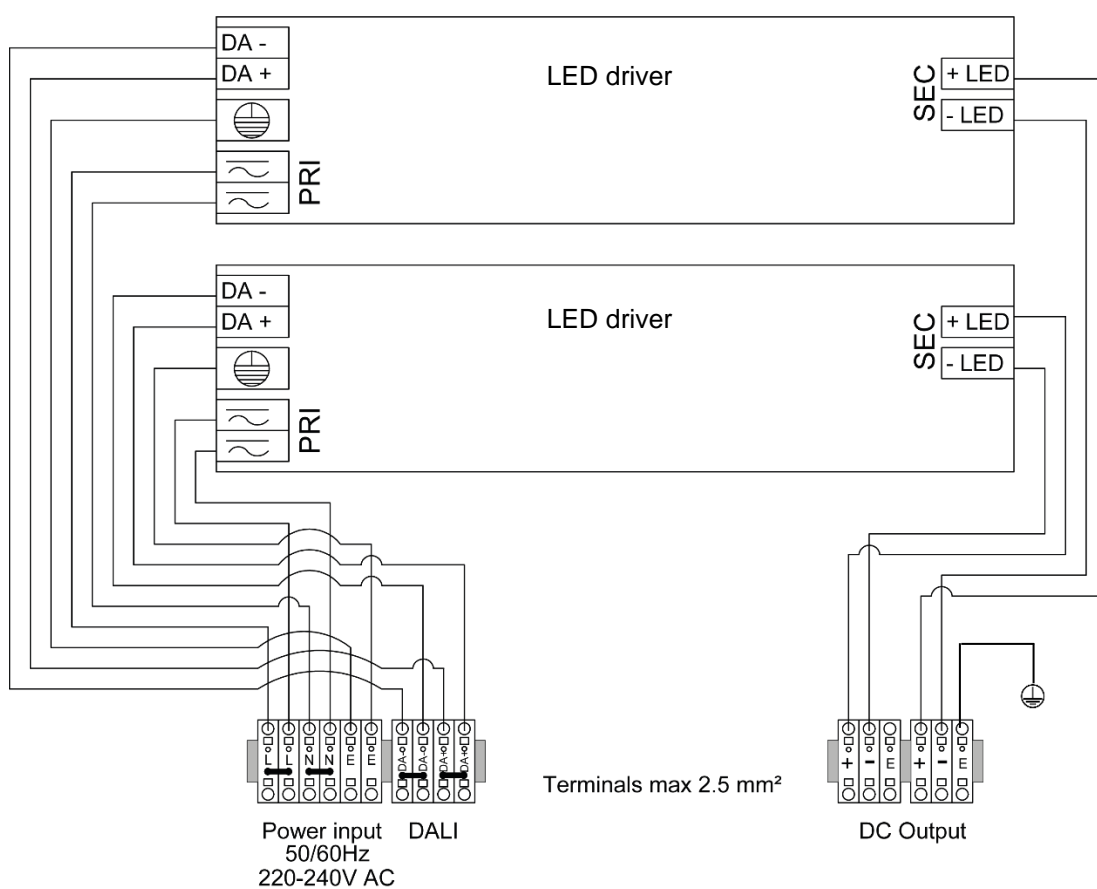

Floodlight 5010: 2 modules

14. Accessories/ spare parts

Use only original WISKA accessories and spare parts. Accessories and spare parts (e.g. cable glands, pressure compensation plugs, seals). They can be obtained from WISKA Service.

Spare parts

No.	Designation	Article no.
1	LED Light Module*	
	SP-5010 Light Engine MB RAL 9005	22001423
	SP-5010 Light Engine MB RAL 9016	22001424
	SP-5010 Light Engine NB RAL 9005	22001425
	SP-5010 Light Engine NB RAL 9016	22001426
	SP-5010 Light Engine WB RAL 9005	22001427
	SP-5010 Light Engine WB RAL 9016	22001428
2	Mounting Brackets	
	SP-5010 Mounting Bracket for 5010-1x220	22001456
	SP-5010 Mounting Bracket for 5010-2x220	22001457
3	Power Supply 5010-PU	
	SP-5010-PU-1x220W-230 Mounting Plate	22001429
	SP-5010-PU-2x220W-230 Mounting Plate	22001430
	SP-5010 LED Driver 220W (suitable for both 5010-PU-1x220W and 5010-PU-2x220W)	22001431

* MB (medium beam), NB (narrow beam), WB (wide beam)

15. Declaration of Conformity/Certificate

The declaration of conformity for each floodlight can be found on www.wiska.com.

WISKA Hoppmann GmbH
Kisdorfer Weg 28
24568 Kaltenkirchen
Germany

Phone +49 (0) 4191 508-0
Fax +49 (0) 4191 508-249

contact@wiska.de
www.wiska.com

ORIGINAL
Subject to change without notice!

03/2025