

Betriebsanleitung - Operating instructions - Mode d'emploi

Verschlussschrauben

Locking Screws

Bouchons filetés

EX-E*VS ** (LT)(-**) (EADR **/90)



ATEX

UK
CA



WISKA Hoppmann GmbH

Kisdorfer Weg 28 • D-24568 Kaltenkirchen

Tel. / Phone / Tél. +49 (0) 4191 508-100 • Fax +49 (0) 4191 508-249

E-Mail wiska@wiska.de • Internet www.wiska.de

Betriebsanleitung

Anwendung

Die Verschlusschrauben dienen zum Verschließen nicht benutzter Öffnungen elektrischer Betriebsmittel der Zündschutzart "e" und "t".

Zweck dieser Anleitung

Bei Arbeiten in explosionsgefährdeten Bereichen hängt die Sicherheit von Personen und Anlagen von der Einhaltung aller relevanten Sicherheitsvorschriften ab. Das Montage- und Wartungspersonal, welches in solchen Anlagen arbeitet, trägt deshalb eine besondere Verantwortung. Die Voraussetzung dafür ist die genaue Kenntnis der geltenden Vorschriften und Bestimmungen. Diese Anleitung fasst kurz die wichtigsten Sicherheitsmaßnahmen zusammen. Sie ergänzt die entsprechenden Vorschriften, zu deren Studium das verantwortliche Personal verpflichtet ist.

Änderungen vorbehalten.



Sicherheitshinweise Safety instructions Consignes de sécurité

Verwenden Sie die Verschlusschrauben nur für den zugelassenen Einsatzzweck. Fehlerhafter oder unzulässiger Einsatz sowie das Nichtbeachten der Hinweise dieser Betriebsanleitung schließen eine Gewährleistung unsererseits aus. Umbauten und Veränderungen an den Verschlusschrauben, die den Explosionsschutz beeinträchtigen, sind nicht gestattet. Die Verschlusschrauben darf nur im unbeschädigten und sauberen Zustand betrieben werden.

Bei Errichtung und Betrieb ist Folgendes zu beachten:

- nationale Sicherheitsvorschriften
- nationale Unfallverhütungsvorschriften
- nationale Montage- und Errichtungsvorschriften (z.B. IEC 60079-14)
- allgemein anerkannte Regeln der Technik
- Sicherheitshinweise dieser Betriebsanleitung
- Kennwerte auf den Verschlusschrauben

Beschädigungen können den Explosionsschutz aufheben.



Eine Kopie der Baumusterprüfbescheinigung zusammen mit der zugehörigen Anlage senden wir Ihnen auf Anfrage gerne zu. If required, we will provide a copy of the Type-Test Certificate with the relevant annex. Une copie du certificat de conformité aux normes ainsi que les annexes correspondantes sont disponibles sur simple demande.

Operating instructions

Application

The locking screws are used to close unused openings of electrical equipment of the "e" and "t" protection type.

Purpose of these instructions

Working in hazardous areas, the safety of personnel and plant depends on complying with all relevant safety regulations. Assembly and maintenance staff working on installations therefore have a particular responsibility. They require precise knowledge of the applicable standards and regulations. These instructions give a brief summary of the most important safety measures. It supplements the corresponding regulations which the staff responsible must study.

Subject to alteration.

Use the locking screws only for its intended purpose. Incorrect or impermissible use or non-compliance with these instructions invalidates our warranty provision. No changes to the device impairing is explosion protection are permitted. Use the locking screws only if they are clean and undamaged.

Observe the following during installation and operation:

- national safety regulations
- national accident prevention regulations
- national installation regulations (e.g. IEC 60079-14)
- generally recognized technical regulations
- safety guidelines in these operating instructions
- characteristic values given on the locking screws

Any damage can invalidate the Ex-protection.

Mode d'emploi

Utilisation

Les bouchons filetés à vis permettent d'obturer les ouvertures non utilisées de matériels électriques appartenant à la classe de protection "e" et "t".

Objet du présent mode d'emploi

Lors du travail dans des zones à risque d'explosion, la sécurité des personnes et des installations dépend du respect de toutes les consignes de sécurité correspondantes. Le personnel chargé du montage et de la maintenance sur ces équipements possède à cet égard une grande responsabilité et doit connaître parfaitement les prescriptions et dispositions légales en vigueur. Le présent mode d'emploi résume de façon concise les mesures de sécurité les plus importantes. Il ne peut en aucun cas se substituer aux prescriptions correspondantes, dont l'étude demeure obligatoire pour le personnel responsable.

Sous réserve de modifications.

Les bouchons filetés ne doivent être utilisés que pour l'application pour laquelle elle ont été prévus. Une utilisation défectueuse ou anormale ainsi que le non-respect des consignes du présent mode d'emploi excluent toute clause de garantie. Les modifications sur les bouchons filetés, susceptibles d'entraver la protection antidéflagrante, ne sont pas autorisées. Ne pas monter les bouchons filetés si elles sont endommagées ou sales.

Lors du montage et du fonctionnement, veuillez observer les points suivants:

- les prescriptions nationales de sécurité
- les prescriptions nationales en matière de prévention des accidents
- les instructions nationales de montage (par. Ex. CEI 60079-14)
- les règles de l'art dans le domaine technique
- les consignes de sécurité du présent mode d'emploi
- les caractéristiques techniques indiquées sur les bouchons filetés

Toute détérioration de matériel peut avoir pour conséquence de rendre inopérante la protection antidéflagrante.

Betriebsanleitung	Operating instructions	Mode d'emploi
-------------------	------------------------	---------------

1 Normenkonformität

Die Verschlusschraube entspricht folgenden Bestimmungen und Normen:

- Richtlinie 2014/34/EU
- UKSI 2016:1107 (as amended by UKSI 2019:696) – Schedule 3A, Part 1
- IEC 60079-0:2017 (EN 60079-0:2018)
- IEC 60079-7:2015 (EN 60079-7:2015)
- IEC 60079-31:2013 (EN 60079-31:2014)

Die Verschlusschraube Typ EX-E*VS ** (LT)(-**) (EADR **/90) ist für den Einsatz in explosionsgefährdeten Bereichen der Zonen 1, 21, 2 und 22 zugelassen.

2 Technische Daten

Explosionsschutz:

Prüfzertifikate:

Material:

- EX-EMVS ** (LT)
- EX-EMVS ** (LT)-A2
- EX-EMVS ** (LT)-A4

Umgebungstemperatur:

- EX-E*VS ** (-**) -40°C....+120°C
- EX-E*VS ** **LT**(-**) -60°C....+120°C
- EX-E*VS ** (-**) EADR **/90 -40°C....+75°C

Schutzart nach IEC 60529:

Empfohlene Drehmomente:

Größe der Verschlusschrauben / Locking screws size / Filetage des bouchons filetés

- M12x1,5
- M16x1,5
- M20x1,5
- M25x1,5
- M32x1,5
- M40x1,5
- M50x1,5
- M63x1,5

1 Conformity to standards

The locking screws complies with the following regulations and standards:

- Directive 2014/34/EU
- UKSI 2016:1107 (as amended by UKSI 2019:696) – Schedule 3A, Part 1
- IEC 60079-0:2017 (EN 60079-0:2018)
- IEC 60079-7:2015 (EN 60079-7:2015)
- IEC 60079-31:2013 (EN 60079-31:2014)

Locking screws type EX-E*VS ** (LT)(-**) (EADR **/90) is suitable for use in hazardous areas of Zones 1, 21, 2 and 22.

2 Technical Data

Explosion protection:

II 2 G Ex eb IIC Gb / II 2 D Ex tb IIIC Db

Test certificate:

IECEX PTB 14.0024, PTB 05 ATEX 1106, UL22UKEX2675

Material:

- Messing / brass / laiton
- Edelstahl / Stainless steel / Acier special
- Edelstahl / Stainless steel / Acier spécial

Ambient temperature:

- O-Ring EPDM, schwarz / O-ring EPDM, black / O-ring EPDM, noir
- O-Ring Silikon, rot und blau / O-ring silicon, red and blue / O-ring silicon, rouge et bleu
- Flachdichtung EPDM, schwarz / Flat seal EPDM, black / Joint plat EPDM, noir

Degree of protection to IEC 60529:

IP66/68 (5bar; 30min)

Recommended torques:

1 Conformité aux normes

Les bouchons filetés sont conformes aux prescriptions et normes suivantes:

- Directive 2014/34/UE
- UKSI 2016:1107 (as amended by UKSI 2019:696) – Schedule 3A, Part 1
- IEC 60079-0:2017 (EN 60079-0:2018)
- IEC 60079-7:2015 (EN 60079-7:2015)
- IEC 60079-31:2013 (EN 60079-31:2014)

L'utilisation des bouchons filetés EX-E*VS ** (LT)(-**) (EADR **/90) est autorisée en atmosphère explosible des zones 1, 21, 2 et 22.

2 Caractéristiques techniques

Protection antidéflangrante:

Certificat de conformité:

Matériau:

- 2.0401 (Ms58, CuZn39Pb3, CW614N)
- 1.4305 (A2, X8CrNiS18-9, AISI 303)
- 1.4435 (A4, X2CrNiMo18-14-3, AISI 316L)

Température ambiante:

- O-Ring EPDM, schwarz / O-ring EPDM, black / O-ring EPDM, noir
- O-Ring Silikon, rot und blau / O-ring silicon, red and blue / O-ring silicon, rouge et bleu
- Flachdichtung EPDM, schwarz / Flat seal EPDM, black / Joint plat EPDM, noir

Degré de protection d'après CEI 60529:

Couples recommandés:

- M [Nm]
- 2,0
- 2,0
- 2,0
- 5,0
- 5,0
- 10,0
- 10,0
- 10,0

3 Montage

Maßskizze

3 Fitting

Dimensions

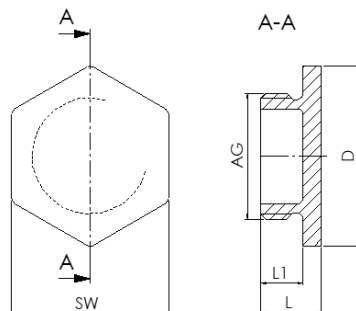

3 Montage

Plan d'encombrement

Typ / Type / Type	AG	SW [mm]	D [mm]	L [mm]	L1 [mm]
EX-E*VS 12 (LT)(-**) (EADR **/90)	M12x1,5	14	15,7	7,5	5
EX-E*VS 16 (LT)(-**) (EADR **/90)	M16x1,5	18	20,3	8	5
EX-E*VS 20 (LT)(-**) (EADR **/90)	M20x1,5	22	24,9	9	6
EX-E*VS 25 (LT)(-**) (EADR **/90)	M25x1,5	28	31,8	10	6,5
EX-E*VS 32 (LT)(-**) (EADR **/90)	M32x1,5	35	39,9	10,5	7
EX-E*VS 40 (LT)(-**) (EADR **/90)	M40x1,5	44	50,3	12	8
EX-E*VS 50 (LT)(-**) (EADR **/90)	M50x1,5	54	61,9	15	9
EX-E*VS 63 (LT)(-**) (EADR **/90)	M63x1,5	67	76,9	16	10

Anschlussmaße der Geräte

Connection dimensions of the devices

Dimensions de raccordement des appareils

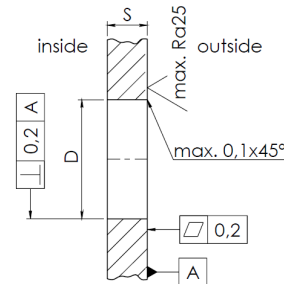
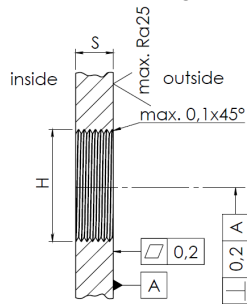

Wandstärke mit Gewindebohrung / Wall thickness with threaded hole / Épaisseur de la paroi avec trou fileté

H	Norm / standard / norme	Metallgehäuse / Metal housings / Boîtier en métallique	Kunststoffgehäuse / Plastic housings / Boîtier en plastique
M12x1,5			
M16x1,5			
M20x1,5			
M25x1,5			
M32x1,5	ISO 965	≥ 3mm	≥ 4mm
M40x1,5			
M50x1,5			
M63x1,5			

Wandstärke mit Durchgangsbohrung / Wall thickness with through-hole / Épaisseur de la paroi avec trou traversant

D [mm]	Metallgehäuse / Metal housings / Boîtier en métallique	Kunststoffgehäuse / Plastic housings / Boîtier en plastique	Minimale Dicke der Metallmutter / minimum metal nut depth / Épaisseur minimale de écrou en métal
12,0+0,2	(1,0 - 2,0)mm	2,0mm	2,8mm
16,0+0,2	(1,0 - 2,0)mm	2,0mm	2,8mm
20,0+0,2	(1,0 - 3,0)mm	(2,0 - 3,0)mm	3,0mm
25,0+0,2	(1,0 - 3,0)mm	(2,0 - 3,0)mm	3,5mm
32,0+0,2	(1,0 - 3,0)mm	(2,0 - 3,0)mm	4,0mm
40,0+0,2	(1,0 - 3,0)mm	(2,0 - 3,0)mm	5,0mm
50,0+0,2	(1,0 - 4,0)mm	(2,0 - 4,0)mm	5,0mm
63,0+0,2	(1,0 - 4,0)mm	(2,0 - 4,0)mm	6,0mm



Bei anderen vom Standard abweichenden Betriebsbedingungen nehmen Sie Rücksprache mit dem Hersteller. /
Please consult the manufacturer if operating conditions are non-standard. /
En cas de conditions d'utilisation différentes, veuillez contacter le constructeur.

Die Verantwortung hinsichtlich bestimmungsgemäßer Verwendung dieser Verschlusschrauben unter Bezugnahme der in der Anlage vorhandenen Rahmenbedingungen liegt allein beim Betreiber

The user alone is responsible for the appropriate use of this locking screws in consideration of the basic conditions existing at the plant.

L'utilisation conforme aux dispositions de ces bouchons filetés, en tenant compte des conditions cadre existants dans l'installation, est laissé à la seule responsabilité de l'exploitant.

Transport und Lagerung sind nur in Originalverpackung gestattet.

Transport and storage is permitted only in the original packaging.

Le transport et le stockage sont autorisés uniquement en emballage d'origine.

Betriebsanleitung

4 Inbetriebnahme

Bevor Sie ein Gerät zusammen mit der Verschlusschraube in Betrieb nehmen, stellen Sie sicher dass:

- die Verschlusschraube nicht beschädigt ist
- der O-Ring für die Schutzart IP68 vorhanden ist
- die Verschlusschrauben gemäß der empfohlenen Drehmomente angezogen sind
- die Auflageflächen für die Dichtungen plan sind

Unsachgemäße Installation und Betrieb führt zum Verlust der Garantie.

5 Wartung



Beachten Sie die geltenden nationalen Bestimmungen im Einsatzland! /
Observe the relevant national regulations for your country! /
Observez les réglementations en vigueur dans le pays d'utilisation!

Bei Wartungsarbeiten sind folgende Punkte zu überprüfen:

- Einhaltung der zulässigen Temperaturen (gemäß IEC 60079-0)
- Risse an der Verschlusschraube
- Beschädigungen der Dichtungen

Operating instructions

4 Commissioning

Before commissioning equipment fitted with locking screws, ensure that:

- the locking screw is not damaged
- the O ring for IP68 is available
- the locking screws have been tightened to the recommended torque values
- the gasket bearing areas are flat

Improper installation and operation leads to loss of warranty.

5 Maintenance

The following points must be checked during maintenance:

- compliance with permitted temperatures (to IEC 60079-0)
- cracks in the locking screws
- damage to the gaskets

Mode d'emploi

4 Mise en service

Avant la mise en service d'un appareil avec des bouchons filetés, assurez-vous des points suivants:

- les bouchons filetés ne sont pas endommagés
- la rondelle obturatrice pour le degré de protection IP68 a été utilisée
- les bouchons filetés sont serrés conformément au couple recommandée
- les surfaces de contact pour les joints sont planes

Une installation et une exploitation incorrectes conduisent à la perte de la garantie.

5 Maintenance

Lors des travaux d'entretien, les points suivants doivent être contrôlés:

- le maintien des températures autorisées (selon IEC 60079-0)
- la présence éventuelle de fissures sur les bouchons filetés
- la détérioration des joints d'étanchéité

6 Zubehör / Ersatzteile

6 Accessories / Spare parts

6 Accessoires / Pièces de rechange



Verwenden Sie nur Original-Zubehör sowie Original-Ersatzteile der Fa. WISKA. /
Use only original spare parts as well as original accessories made by WISKA. /
Utilisez uniquement des pièces de rechange et des accessoires d'origine de WISKA.

	Typ / Type / Type	Bestellnummer / Order number / Référence	Typ / Type / Type	Bestellnummer / Order number / Référence
	O-Ring für die Normaltemperaturvariante ¹⁾ / O-ring for the normal temperature variant ¹⁾ / O-ring pour la variation de la température normale ¹⁾		Flachdichtung für die Normaltemperaturvariante ¹⁾ / flat gasket for the normal temperature variant ¹⁾ / Joint torique d'étanchéité pour la variation de la température normale ¹⁾	
EX-EMVS 12	ORD-E 12	10064697	EADR 12	10062801
EX-EMVS 16	ORD-E 16	10064698	EADR 16	10062802
EX-EMVS 20	ORD-E 20	10064699	EADR 20	10062803
EX-EMVS 25	ORD-E 25	10064700	EADR 25	10062804
EX-EMVS 32	ORD-E 32	10064701	EADR 32	10062805
EX-EMVS 40	ORD-E 40	10064702	EADR 40	10062806
EX-EMVS 50	ORD-E 50	10064703	EADR 50	10062807
EX-EMVS 63	ORD-E 63	10064704	EADR 63	10062808
	O-Ring für die LT Variante ¹⁾ / O-ring for the LT variant ¹⁾ / O-ring pour la variante LT ¹⁾		Flachdichtung für die LT Variante ¹⁾ / flat gasket for the LT variant ¹⁾ / Joint torique d'étanchéité pour la variante LT ¹⁾	
EX-EMVS 12 LT	ORD-S 12	10101757	EADR 12/90 LT	10105704
EX-EMVS 16 LT	ORD-S 16	10101758	EADR 16/90 LT	10105705
EX-EMVS 20 LT	ORD-S 20	10101759	EADR 20/90 LT	10105706
EX-EMVS 25 LT	ORD-S 25	10101760	EADR 25/90 LT	10105707
EX-EMVS 32 LT	ORD-S 32	10101761	EADR 32/90 LT	10105708
EX-EMVS 40 LT	ORD-S 40	10101762	EADR 40/90 LT	10105709
EX-EMVS 50 LT	ORD-S 50	10101763	EADR 50/90 LT	10105710
EX-EMVS 63 LT	ORD-S 63	10101764	EADR 63/90 LT	10105711
	Gegenmutter - Metall ²⁾ / Lock nut - Metal ²⁾ / contre-écrou - Métal ²⁾			
EX-EMVS 12 (LT)	EMMU 12	10063141		
EX-EMVS 16 (LT)	EMMU 16	10063142		
EX-EMVS 20 (LT)	EMMU 20	10063143		
EX-EMVS 25 (LT)	EMMU 25	10063144		
EX-EMVS 32 (LT)	EMMU 32	10063145		
EX-EMVS 40 (LT)	EMMU 40	10063146		
EX-EMVS 50 (LT)	EMMU 50	10063147		
EX-EMVS 63 (LT)	EMMU 63	10063148		

¹⁾ Die Dichtungen dienen als Zusatzdichtung zum Erreichen der Schutzart IP66/68 / The gaskets act as additional sealing to achieve the IP66/68 protection degree / Les d'étanchéité servent de joints supplémentaires pour atteindre la classe de protection IP66/68.

²⁾ Die Gegenmutter dient zum Befestigen der Verschlusschrauben in Durchgangslöchern. / The lock nut is used to secure the locking screws in position. / Le contre-écrou est utilisé pour fixer bouchons filetés dans les trous de passage.

7 Entsorgung

7 Disposal

7 Réglementation concernant les déchets



Beachten Sie die nationalen Abfallbeseitigungsvorschriften. /
Observe the national standard for refuse disposal. /
Respectez les réglementations nationales en matière d'élimination des déchets.



Für spezielle Fragen stehen wir Ihnen gerne zur Verfügung. /
We are pleased to answer any special questions you may have. /
Nous sommes à votre disposition pour tout renseignement complémentaire.

Sollten Sie die Bedienungsanleitung in einer der anderen Sprachen der Europäischen Gemeinschaft benötigen, wenden Sie sich bitte an Ihren WISKA-Vertreter.

Should you require the operating instructions in one of the other European Community languages, please feel free to contact your WISKA representative.

Si vous avez besoin des instructions de mise en service dans une autre langue de l'Union Européenne, prière de contacter votre Représentant WISKA.

Se for necessária a tradução destas instruções de operação para outro idioma da União Europeia, pode solicita-la junto do seu representante WISKA.

En översättning av denna montageoch skötselinstruktion till annat EU-språk kann vid behov beställas från er WISKA representant.

En caso necesario podrá solicitar de su representante WISKA estas instrucciones de servicio en otro idioma de la Union Europea.

Montagevejledningen kan oversættes til andre EU-sprog og rekvireres hos deres WISKA leverandør.

Se desiderate la traduzione del manuale operativo in un'altra lingua della Comunità Europea potete richiederla al vostro rappresentante WISKA.

Tarvittaessa tämän käyttöohjeen käännös on saatavissa toisella EU:n kielellä Teidän WISKA-edustajaltanne.

Indien noodzakelijk kan de vertaling van deze gebruiksinstructie in een andere EU-taal worden opgevraagd bij uw WISKA-vertegenwoordiging.



(1) EU-TYPE EXAMINATION CERTIFICATE (Translation)

- (2) Equipment or Protective Systems Intended for Use in Potentially Explosive Atmospheres - Directive 2014/34/EU
(3) EU-Type Examination Certificate Number: PTB 05 ATEX 1106
(4) Product: Threaded blanking element type EX-''VS(-L)''
(5) Manufacturer: WISKA Hoppmann GmbH
(6) Address: Kisdorfer Weg 28, 24568 Kaltenkirchen, Germa
(7) This product and any acceptable variation thereto is specified in the sचे documents therein referred to.
(8) The Physikalisch-Technische Bundesanstalt, notified body No. 0102 in ac Directive 2014/34/EU of the European Parliament and of the Council, dated this product has been found to comply with the Essential Health and Safe design and construction of products intended for use in potentially explosiv II to the Directive.
(9) Compliance with the Essential Health and Safety Requirements has been EN IEC 60079-0:2018, EN IEC 60079-7:2015+A1:2018, EN 60079-
(10) If the sign "X" is placed after the certificate number, it indicates that the pr Conditions of Use specified in the schedule to this certificate.
(11) This EU-Type Examination Certificate relates only to the design and const in accordance to the Directive 2014/34/EU. Further requirements of the Dire process and supply of this product. These are not covered by this certificat
(12) The marking of the product shall include the following:

II 2 G Ex eb IIC Gb
II 2 D Ex tb IIIC Db

Konformitätsbewertungsstelle, Sektor Explosionsschutz

On behalf of PTB:
Dr.-Ing. D. Markus
Direktor und Professor

EU-Type Examination Certificates without signature and official stamp shall not be valid. Only without alteration. Extracts or alterations are subject to approval by the Physikalisch In case of dispute, the German text shall prevail.

Physikalisch-Technische Bundesanstalt • Bundesallee 100 • 38116 Braunschweig

IECEx Certificate of Conformity
INTERNATIONAL ELECTROTECHNICAL COMMISSION
IEC Certification System for Explosive Atmospheres
Certificate No.: IECEx PTB 14.0024
Status: Current
Date of issue: 2022-06-28
Applicant: WISKA Hoppmann GmbH
Equipment: Threaded blanking element EX-''VS(-L)'' (LT)(-'' (ADR ''90))
Type of Protection: "eb", "tb"
Marking: Ex eb IIC Gb
Ex tb IIIC Db
Approved for issue on behalf of the IECEx Certification Body: Dr.-Ing. Detlev Markus
Head of Department "Explosion Protect"
Signature: D. Markus
Date: 28.06.22

UNITED KINGDOM CONFORMITY ASSESSMENT
UK-TYPE EXAMINATION CERTIFICATE

- (1) Product or Protective System Intended for Use in Potentially Explosive Atmospheres UKSI 2016:1107 (as amended by UKSI 2019:696) - Schedule 3A, Part 1
(2) UK-Type Examination Certificate No.: UL22UKEX2675 Rev. 0
(3) Product: Threaded blanking element type EX-''VS(-L)'' (LT)(-'' (ADR ''90))
(4) Manufacturer: WISKA Hoppmann GmbH
(5) Address: Kisdorfer Weg 28, 24568 Kaltenkirchen, Germany
(6) This product and any acceptable variation thereto are specified in the schedule to this certificate and the documents therein referred to.
(7) UL International (UK) Ltd, Approved Body number 0843, in accordance with Regulation 44 of the Equipment and Protective Systems Intended for Use in Potentially Explosive Atmospheres Regulations 2016, UKSI 2016: 1107 (as amended by UKSI 2019:696), certifies that this product has been found to comply with the Essential Health and Safety Requirements relating to the design and construction of products intended for use in potentially explosive atmospheres given in Schedule 1 of the Regulations.
(8) The examination and test results are recorded in the confidential report DEPTB/EXTR14.0027/01.
(9) Compliance with the Essential Health and Safety Requirements has been assured by compliance with: EN IEC 60079-0:2018 EN IEC 60079-7:2015+A1:2018 EN 60079-31:2014
(10) Except in respect of those requirements listed at section 19 of the schedule to this certificate.
(11) If the sign "X" is placed after the certificate number, it indicates that the product is subject to the Specific Conditions of Use specified in the Schedule to this certificate.
(12) This UK-TYPE EXAMINATION CERTIFICATE relates only to the design and construction of the specified product. Further requirements of the Regulations apply to the manufacturing process and supply of this product. These are not covered by this certificate.
(13) The marking of the product shall include the following:

II 2 G Ex eb IIC Gb
II 2 D Ex tb IIIC Db

Certification Officer
Andrew Moffat

This is to certify that the samples of the Product described herein ("Certified Product") has been investigated and found in compliance with the Standards indicated on this Certificate. In accordance with the UKCA Product Certification Program Requirements. This certificate and test results obtained apply only to the product samples submitted by the manufacturer. It does not extend to samples of other products or other samples provided were representative of other manufactured product. UL has not established Follow-Up Service or other services of the product. The manufacturer is solely responsible for compliance of the product to all applicable standards, specifications, requirements or Regulations. The test results may not be used, in whole or in part, in any other document without the prior written approval.

Approved Body
UL International (UK) Ltd Unit 1-3 Horizon Kingsland Business Park Wade Road, Basingstoke RG24 8AH, UK
Phone : +44 (0)1256 312100

Form-ULD-009123.1 - Issue 4.0

A UKAS accredited certification body No. 4705
This certificate may only be reproduced in its entirety and without any change, schedule included.



Page 1 of 4



EU DECLARATION OF CONFORMITY



WISKA Hoppmann GmbH
Kisdorfer Weg 28
24568 Kaltenkirchen
Germany



KCEI-21051-0

Declares under its sole responsibility that:

Product designation: Screw plug
Type designation: EX-''VS(-L)'' (LT)(-''
Description: Screw plug for electrical installation
Approval number/Production Quality Assessment: PTB 05 ATEX 1106 PTB 03 ATEX Q044
Notification:

Information about the product

Marking
II 2 G Ex eb IIC Gb
II 2 D Ex tb IIIC Db

Ambient temperature: Standard Type: -40°C ... +75°C
LT Type: -60°C ... +75°C
with *ADR: -40°C ... +75°C

corresponds to all the relevant provisions of the directives listed below and valid harmonized and / or international and national standards - including all applicable changes at this time of issuing this document.

Table with 2 columns: Regulation, Standard. Rows include 2014/34/EU Equipment and protective systems, Other Standards, and 2011/65/EU Restriction of the use of certain hazardous substances.

WISKA Hoppmann GmbH
Kaltenkirchen, Germany

Signature of Head of Engineering & Design

2023-02-24

Head of Engineering & Design

DECLARATION OF CONFORMITY



WISKA Hoppmann GmbH
Kisdorfer Weg 28
24568 Kaltenkirchen
Germany



KGBI-21051-0

Declares under its sole responsibility that:

Product designation: Screw plug
Type designation: EX-''VS(-L)'' (LT)(-''
Description: Screw plug for electrical installation
Approval number: UL22UKEX2675 Rev. 0
Production Quality Assessment Notification: UL22UKQAN19164

Information about the product

Marking
II 2 G Ex eb IIC Gb
II 2 D Ex tb IIIC Db

Ambient temperature: Standard Type: -40°C ... +75°C
LT Type: -60°C ... +75°C
with *ADR: -40°C ... +75°C

corresponds to all the relevant provisions of the directives listed below and valid harmonized and / or international and national standards - including all applicable changes at this time of issuing this document.

Table with 2 columns: Regulation, Standard. Rows include UKSI 2016: 1107 (Equipment and Protective Systems Intended for use in Potentially Explosive Atmospheres, Other Standards, and S.I. 2012 No. 3032 The Restriction of the Use of Certain Hazardous Substances in Electrical and Electronic Equipment Regulations 2012.

WISKA Hoppmann GmbH
Kaltenkirchen, Germany

Signature of Head of Engineering & Design

2023-02-24

Head of Engineering & Design

WISKA UK Ltd
St. Columb Major, Great Britain

Signature of Authorised Representative

Authorised Representative

